

TECHNICAL MANUAL

**OPERATOR'S, UNIT, DIRECT SUPPORT
AND GENERAL SUPPORT MAINTENANCE MANUAL
(INCLUDING REPAIR PARTS AND SPECIAL TOOLS LIST)
FOR
WEAPONS SECURITY CAGE XH-4289 (WSC)
(NSN 8140-01-185-3285)**

DISTRIBUTION STATEMENT A: Approved for public release; distribution is unlimited.

HEADQUARTERS, DEPARTMENT OF THE ARMY

DECEMBER 1993

When applicable, insert latest change pages and dispose of superseded pages in accordance with applicable regulations.

LIST OF EFFECTIVE PAGES

TOTAL NUMBER OF PAGES IN THIS PUBLICATION IS 60
CONSISTING OF THE FOLLOWING:

<i>Page No.</i>	<i>*Change No.</i>
Cover	0
Inside Cover blank	0
A and B	0
i and ii	0
1-1 thru 1-8	0
2-1 thru 2-10	0
3-1 thru 3-4	0
A-1 thru A-4	0
B-1 thru B-20	0
C-1 thru C-6	0
D-1 and D-2	0
Authentication Page	0

* Zero indicates an original page.

THIS PAGE INTENTIONALLY LEFT BLANK

TECHNICAL MANUAL)
)
 No. 9-8140-381-14&P)

HEADQUARTERS
 DEPARTMENT OF THE ARMY
 Washington, DC, 23 December 1993

**OPERATOR'S, UNIT, DIRECT SUPPORT,
 AND GENERAL SUPPORT MAINTENANCE MANUAL
 (INCLUDING REPAIR PARTS AND SPECIAL TOOLS LISTS)
 FOR
 WEAPONS SECURITY CAGE XH-4289 (WSC)
 (NSN 8140-01-185-3285)**

REPORTING OF ERRORS

You can help improve this manual. If you find any mistakes or if you know of a way to improve the procedures, please let us know. Mail your letter, DA Form 2028 (Recommended Changes to Publications and Blank Forms), or DA Form 2028-2 located in the back of this manual direct to Commander, US Army Armament Research, Development and Engineering Center; ATTN: SMCAR-LSB, Picatinny Arsenal, NJ 07806-5000. A reply will be furnished directly to you.

		Page
CHAPTER 1	INTRODUCTION	
Section	I. General	
	1-1. Scope	1-1
	1-2. General	1-1
	1-3. Reporting of Equipment Manual Improvements	1-1
Section	II. Weapon Security Cage	
	1-4. Description.....	1-2
Section	III. Operating Procedures	
	1-5. Moving Cage on its Casters	1-3
	1-6. Opening WSC	1-5
	1-7. Closing WSC	1-7
	1-8. Locking WSC.....	1-7
	1-9. Handling/Tiedown of WSC	1-7
	1-10. Inspection	1-7
CHAPTER 2	MAINTENANCE PROCEDURES	
Section	I. Casters	
	2-1. Removing/Installing Caster	2-1
	2-2. Caster Lubrication	2-1
	2-3. Caster Brake Adjustment	2-1
	2-4. Removing/Installing Caster Shoulder Bolt Procedures	2-2
	2-5. Hinge Lubrication	2-3
Section	II. Gas Springs	
	2-6. Removing/Installing Gas Spring	2-4
	2-7. Alternate Gas Spring Removal/Installation Procedure	2-4
Section	III. Combination Lock/Alternate Locks	
	2-8. Description.....	2-5
	2-9. Unlocking.....	2-6
	2-10. Locking.....	2-6
	2-11. Inspection	2-6
	2-12. Maintenance Procedures.....	2-6
	2-13. Three Wheel Lock Installation/Removal.....	2-7

CHAPTER 2	MAINTENANCE PROCEDURES - Continued	
Section	IV. Replacing/Installing Latch	
	2-14. Procedures	2-8
Section	V. Removing/Installing Quick Release Pin and Chain Assembly	
	2-15. Procedures	2-8
Section	VI. Safety Bracket	
	2-16. Removing/Installing Safety Bracket.....	2-8
	2-17. Repair of Safety Bracket Assembly.....	2-9
CHAPTER 3	WEAPON SECURITY CAGE VARIATIONS IN USE	
	3-1. General	3-1
	3-2. Locking Applications	3-1
	3-3. Internal Configuration of WSC	3-3
APPENDIX A.	GENERAL MAINTENANCE PROCEDURES	A-1
APPENDIX B.	REPAIR PARTS AND SPECIAL TOOLS LIST	B-1
APPENDIX C.	MAINTENANCE ALLOCATION CHART (MAC)	C-1
APPENDIX D.	EXPENDABLE AND DURABLE LIST	D-1

LIST OF ILLUSTRATIONS

<u>Figure No.</u>	<u>Title</u>	<u>Page</u>
1-1	Weapon Security Cage	1-2
1-2	Container Casters	1-3
1-3	Wrench Retaining Assembly	1-4
1-4	Opening Combination Lock.....	1-5
1-5	Details of Support Bracket and Gas Spring	1-6
2-1	Caster Lock Lever (Brake) Adjustment	2-1
2-2	Hinge and Mounting from Underside of Cage.....	2-3
2-3	Combination Lock with Protective Cover Rotated	2-5
2-4	Installing Combination Locks.....	2-7
3-1	Alternate Lock Configuration for Weapon Security Cage, XH4289	3-2
3-2	Clamping Configuration for Contents Stored in Weapon Security Cage, XH4289	3-3
A1-1	Weapon Security Cage Marking (Part 1 of 2)	A-2
A1-1	Weapon Security Cage Marking (Part 2 of 2)	A-3
B-1	Weapon Security Cage (Part 1 of 2)	B-8
B-1	Weapon Security Cage (Part 2 of 2)	B-10
B-2	Stay, Folding: Left and Right.....	B-12
B-3	Towbar, Motor Vehicle	B-14

LIST OF TABLES

<u>Table No.</u>	<u>Title</u>	<u>Page</u>
1-1	Inspection of Weapon Security Cage	1-8
2-1	Semi-Annual Inspection of Combination Lock	2-6

CHAPTER 1 INTRODUCTION

Section I. GENERAL

1-1. SCOPE

1-1.1. This technical manual is for all types of ordinance sites, storage structures, and various local applications that will use the weapon security cage (WSC). Included in this manual will be a full description of all active and passive components which make up the WSC.

1-1.2. This manual also contains a repair parts and special tools list (RPSTL) required to operate and maintain the various replacement parts of the WSC.

a. All illustrations shown in this manual where x's are shown i.e., PN xxxx, instead of specific part numbers (PN) and or national stock numbers (NSN), or where parts are called out by name without a part number indicates that this is a specially designed custom part not available through the requisitioning process. Acquisition and distribution of such parts is the responsibility of the U.S. Army Armament Research, Development and Engineering Center (ARDEC). All illustrations of typical items and the item actually used need not conform to the illustrated picture shown in every configurational detail.

b. Parts identified in appendix B (RPSTL) are available in the Federal Supply System and normal requisitioning applies.

c. Tools required for use with parts identified with a PN xxxx which are not available on site, are to be acquired by local purchase. Sizes for the tools are not identified and an underscored blank space followed by the name of the tool (i.e., _____ open-end wrench) is used in the text.

1-2. GENERAL

1-2.1. It is not always feasible or convenient to follow procedures in the sequence provided in this manual. For instance, maintenance may require disassembly for access to only one component, its replacement, and reassembly, although the manual provides a more extensive sequence. The following rule applies unless the manual specifies to the contrary: The organization

may change the sequence of procedures to facilitate operations, if no required tests are omitted, no tests or inspection invalidated, and no safety requirements violated. The sequence of actual electrical test procedures must not be changed.

1-2.2. The recommended maintenance/inspections must be performed at the scheduled intervals to assure system serviceability. It is highly recommended that visual observation of the systems mechanics be conducted each time access to stored materials is required; this visual check is for your safety and should become part of routine operations.

1-2.3. Inspection and preventive maintenance assures serviceability/function for intended use.

1-2.4. During inspections, components will be inspected for obvious visual defects and erratic operation.

1-2.5. Components and parts having damage (such as dents) which would not affect function or in turn damage another part may continue to be used. (Defects should be noted/recorded and reported.)

1-2.6. The term "tighten" when used in this manual means: Use an appropriate tool and with moderate force firmly seat the bolt, nut, or screw. The fastener is considered to be tightened securely if it has reached the point where an increase in force does not result in additional turning of the nut or fastener head. If hardware installation includes a lock washer, tighten sufficiently to compress the lock washer. It is not required to torque fasteners/connections.

1-3. REPORTING OF EQUIPMENT MANUAL IMPROVEMENTS

Reports of errors, omissions, and recommendations for improving this publication by the individual user is encouraged. Reports should be submitted on DA Form 2028 (Recommended Changes to Publications and Blank Forms) and forwarded directly to Commander, U.S. Army Armament Research, Development and Engineering Center, ATTN: SMCAR-LSB, Picatinny Arsenal, New Jersey 07806-5000.

Section II. WEAPON SECURITY CAGE

1-4. DESCRIPTION

1-4.1. XH4289 Weapon Security Cage (fig. 1-1). The XH4289 WSC is a rectangular cage fabricated from structural steel and expanded steel mesh to be used for storing weapon containers or contents. It is mounted on casters for mobility and locked for security with two combination or key locks. The WSC measures 82 x 70 x 43 inches and weighs 1520 pounds. It consists of a

steel pallet base to which an upper container weldment is attached. Access to cage is accomplished by lifting a cover which is hinged along the top of the cage parallel to the rear length of the cage (fig. 1-1). When lifted, this cover permits access to top and entire front surface of cage for easy access to stored contents. Two tiedowns (rings) are located on each of the four sides of the pallet base inside the cage to secure tiedown straps used to secure the WSC contents.

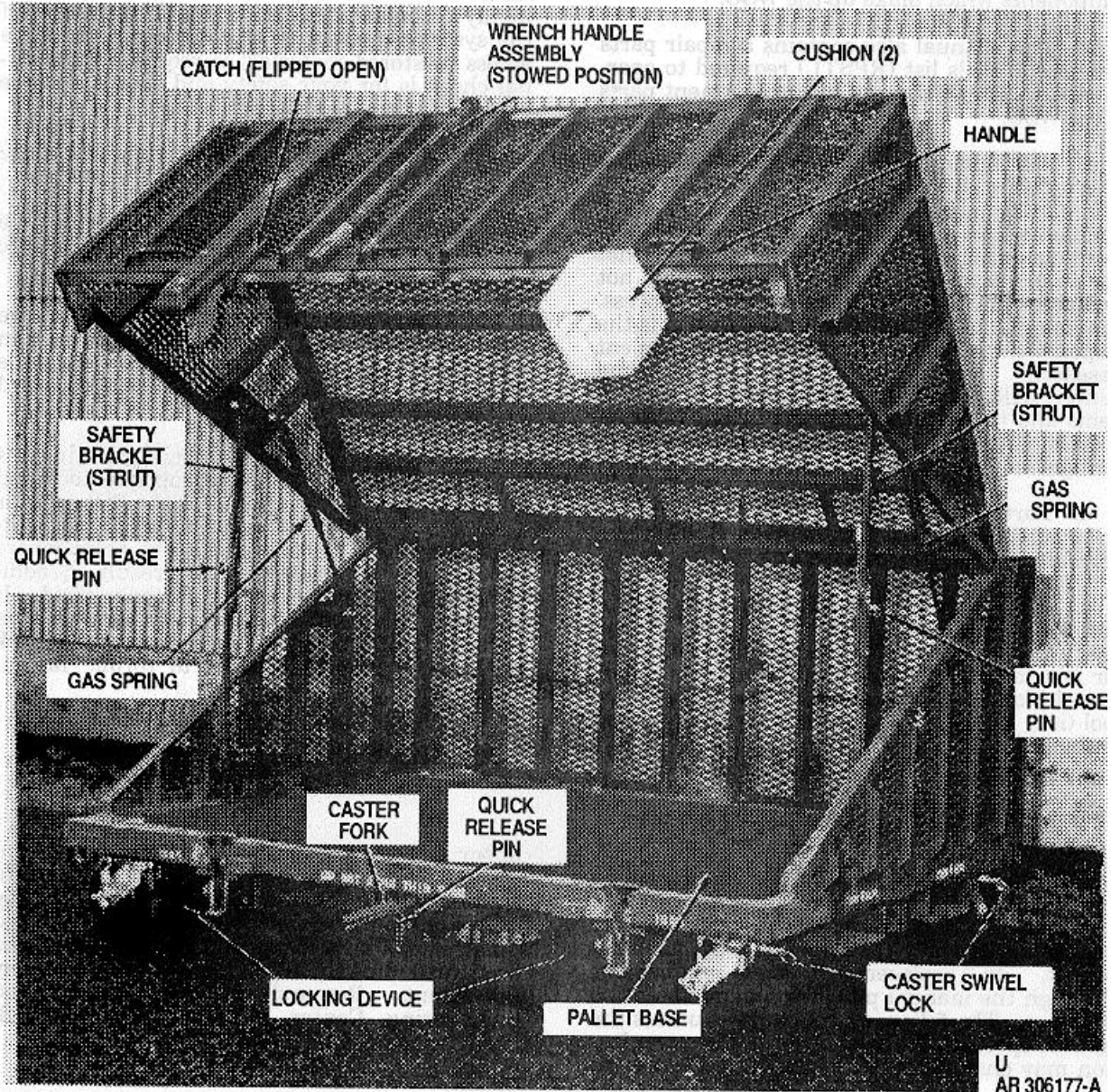

Figure 1-1. Weapon Security Cage.

1-4.2. Wrench Assembly. Each WSC is provided with a wrench assembly which is mounted in a storage bracket on the front of the WSC. The caster fork assembly consists of three major components, the T-handle, caster fork, and clamp tool. The clamp tool when removed from the handle is used to move the sliders of the WSC and to tighten the swivel screws on the clamp. It is removed from the handle by pressing down on a spring button. The caster fork when attached to the handle is used to position the casters. It is stored separate from the handle and is attached to the handle and locked in place by a pin.

1-4.3. Components

1-4.3.1. The WSC is issued as a complete unit but is made up of several operational components (fig. 1-1). The major moving components that make up the WSC are locking devices, caster swivel locks, gas spring, quick release pins, and latches (flipped opened).

1-4.3.2. Maintenance and replacement along with variations in part applications are detailed in the following sections of this technical manual.

Section III. OPERATING PROCEDURES

1-5. MOVING CAGE ON ITS CASTERS

1-5.1. The WSC is provided with four casters for movement over short distances. All four casters have swivel locks to lock the caster wheels in the desired

directions and prevent swiveling. The two front casters also have wheel locks to brake the wheels.

1-5.2. The brakes on the front casters are unlocked by rotating the caster lock lever (fig. 1-2) on the side of each caster counterclockwise until stopped. Front caster wheels may be locked by rotating lock lever clockwise until tight.

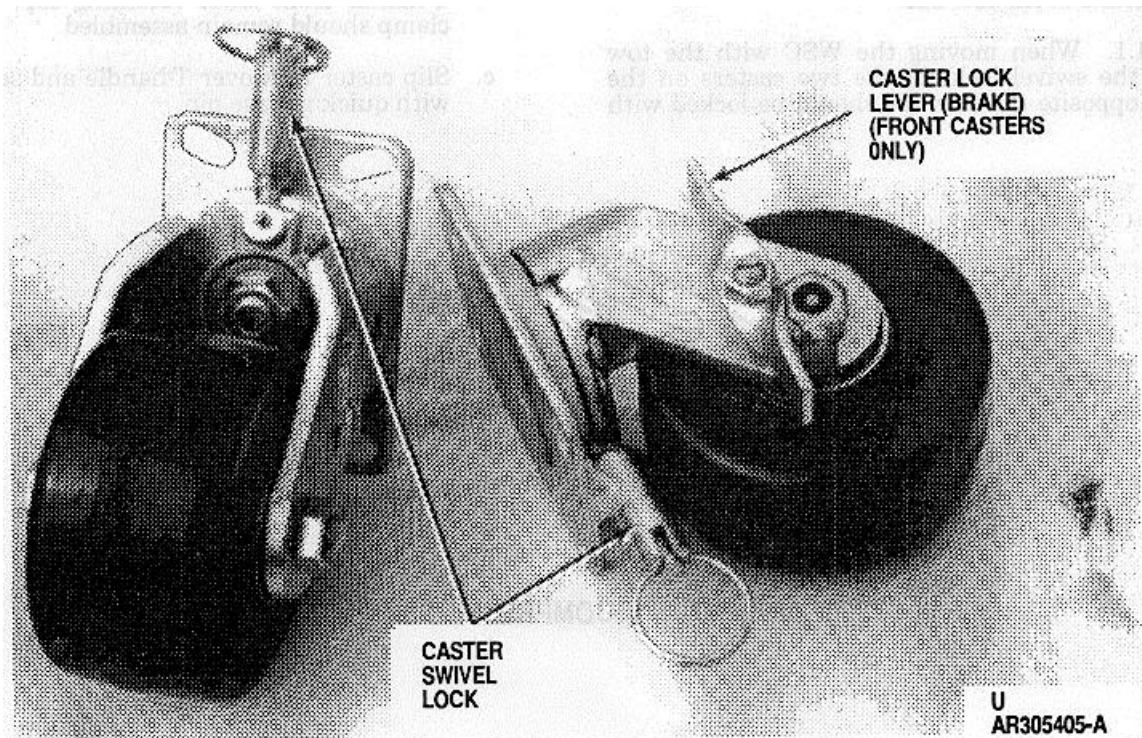

Figure 1-2. Cage Casters.

1-5.3. All casters may be swiveled to position the wheel in the desired direction as follows:

- a. Unlock swivel mechanism by pulling outward on spring-loaded wire ring (fig. 1-2) until it is clear of the deep recess in the swivel lock housing and rotate ring a quarter-turn until it snaps into the shallow recess of the housing.
- b. Rotate caster using caster fork assembled to T-handle (par. 1-5.5). Caster fork is placed around caster wheel.
- c. Lock swivel mechanism by pulling outward on spring-loaded wire ring (fig. 1-2) and rotate ring a quarter-turn until it snaps completely into the deep recess of the swivel lock housing.

WARNING
DO NOT FORK LIFT WSC FROM FRONT SIDE.

1-5.4. The WSC may be moved with or without contents installed for short distances by pushing it using four persons, or between structures within a single storage area by means of a forklift using the designated forklift points, or by means of the tow bar.

1-5.4.1. When moving the WSC with the tow bar, the swivel locks of the two casters on the side opposite the tow bar should be locked with the wheels parallel to the

tow bar length and the other two casters should be free to swivel (unlocked).

1-5.4.2. Towing on site with a tow bar shall be limited to distances not greater than 2 miles at speeds not to exceed 5 miles per hour. Towing may be performed with or without contents installed. There is a tow hitch on each side with the tow bar attached with a quick release pin.

1-5.4.3. When moving the WSC up or down an incline, the two casters on the opposite side from the direction of travel should have their swivels locked with the wheels parallel to the travel direction; the other two caster swivels should be unlocked.

1-5.5. Caster Fork Wrench Assembly Instructions.

- a. Remove caster fork from its storage bracket by removing quick release pin.
- b. Push T-handle with clamp tool toward bottom edge of front face of cage (fig. 1-3) until top of T-handle clears the upper retaining cap. This will be caused by the force of the spring that is captured in the lower retaining cap. Lift and remove T-handle from lower retaining cap. The clamp should remain assembled.
- c. Slip caster fork over T-handle and secure with quick release pin.

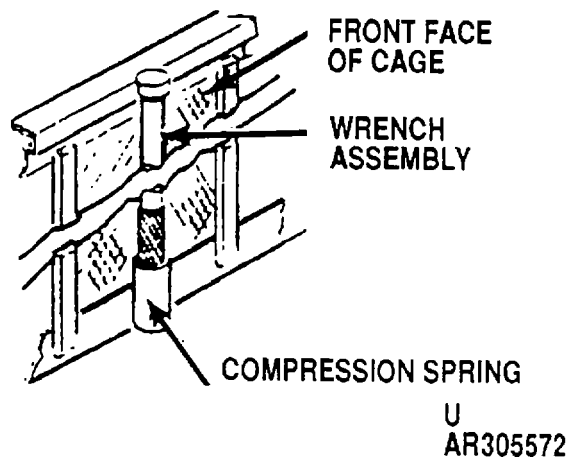

Figure 1-3. Wrench Retaining Assembly

1-6. OPENING WSC

a. Unlock each of the two combination locks as follows (fig. 1-4):

(1) Rotate protective cover away from

combination lock and hold cover against spring tension with one hand.

(2) Rotate each of the three code wheels of combination lock until the correct code is aligned between indexing marks.



Figure 1-4. Opening Combination Lock

- (3) Return protective cover to its original position.
 - (4) Grasp knob on combination lock bolt and pull bolt to the left, until lock is open.
- b. Release two latches attached to front of WSC (fig. 1-1) by pulling handles forward. When both latches are released, WSC cover may lift approximately 1 to 6 inches.
- c. Using two persons, raise cover to open position and secure safety brackets (two each) in place by quick release pins (fig. 1-5).
 - d. Install two tang cushions, one on each container locking tang.



Figure 1-5. Details of Support Bracket and Gas Spring

1-7. CLOSING WSC

- a. Remove the two pads and store them in a convenient location on the pallet base'
- b. Ensure deck plate sliders are in fully engaged position so they do not interfere with locking tangs.

WARNING

TWO PERSONS MUST SUPPORT THE WSC COVER AFTER THE TWO QUICK RELEASE PINS ARE REMOVED UNTIL THE COVER IS LOWERED.

NOTE

The two flat hooks at front of deck plate must be facing inward to ensure proper closing.

- c. Using two persons to support the WSC cover, remove the two quick release pins. Store the quick release pins in the receptacles on the safety brackets (struts).
- d. Pull the hinge section of the safety brackets (struts) forward while slowly lowering the cover.

1-8. LOCKING WSC

- a. Apply a downward force on front of cage cover and engage catches with the strike; secure by moving catch handle down and towards strike until they snap into position.
- b. After catches are secured, push each lock bolt to the right until bolt is seated in housing.
- c. Rotate protective cover to expose code wheels.
- d. Rotate each code wheel on locking device until diamond figures are alined between indexing marks.
- e. Return protective cover to its original position.

- f. Pull knob on lock bolt forcefully to the left to insure bolt is securely locked into position.

1-9. HANDLING/TIEDOWN OF WSC

Handling and lifting can be accomplished by a forklift certified to lift the total weight of the WSC.

NOTE

The external tiedown rings (8 top, 4 bottom) are not to be used for lifting WSC.

1-10. INSPECTION

1-10.1. This section outlines inspection procedures required for the WSC. An initial receipt inspection is not included. Inspection procedures are to be performed on a semi-annual basis beginning when the empty WSC is first received in accordance with table 1-1.

1-10.2. Maintenance required as a result of inspection is shown in table 1-1 and shall be performed in accordance with chapter 2.

1-10.3. Items or components will not be rejected when inspection criteria are applied as long as item (or component) is still serviceable; that is, the item will not impair normal loading or unloading contents operations, violate a safety requirement, or damage any other component as a result of its use. Specific defects which are not cause for rejection are: (1) dents or small holes in the steel mesh, (2) caster wheels which are chipped, flaked, gouged, or have pieces missing which do not impair rolling of the wheel, or (3) scratches or gouges in paint on fork lift tubes, pallet base, or tiedown rings. Paint scratches or gouges exposing base metal in areas other than those listed in (3) above, shall be touched up as deemed necessary. Where judgement is required during an inspection, the person performing the inspection will make the judgment.

1-10.4. Visual inspections shall be accomplished without the aid of magnification.

1-10.5. Removal of foreign materials (mud, salt, water, grease, oil, fungus, etc) and corrosion shall be accomplished in accordance with appendix C.

Table 1-1.
Inspection of Weapon Security Cage

Inspection	Action To Be Taken
1. Casters broken and/or bent; will not roll or swivel*	Replace caster (par. 2-1)
2. Front caster brakes out of adjustment	Adjust (par. 2-3)
3. Cover hinge binding	Lubricate (par. 2-5)
4. Gas spring leaking oil or other loss of lift assist capability (gas springs should enable cage to be opened with a 65 pound lifting force)	Replace gas spring (par. 2-6 or 2-7)
5. Cage paint scratched or gouged	Touch-up, repaint if extensive (appendix C)
6. Foreign matter or corrosion present	Clean as required (appendix C)
7. Latch broken and/or bent. Will not engage properly with strike	Replace latch (par. 2-14)
8. Illegible markings	Replace/repair (fig. C-1 and appendix C)
9. Pads broken or torn	Replace
10. Balls on quick release pins do not release	Replace quick release pin

*Casters should be lubricated semi-annually (par. 2-2).

CHAPTER 2
MAINTENANCE PROCEDURES

CAUTION

Unless otherwise specified, remove all items from cage prior to performing maintenance operations.

Section I. CASTERS

2-1. REMOVING/INSTALLING CASTER

- a. Lock caster brake on side of cage opposite caster being replaced. This is accomplished by rotating caster lock on side of caster clockwise until tight.
- b. Use pallet jack (or forklift) to raise cage at least 9 inches (distance between bottom surface of pallet and floor) off ground.
- c. If pallet jack is used, assure that it is properly engaged.
- d. Remove faulty caster using a 3/4-inch socket and socket wrench. Break loose all four nuts before removing any one nut. Inspect bolt threads for serviceability. Replace if unserviceable.
- e. Check new caster (fig. 1-2) for proper swiveling, free rotation, spring-loaded wire ring operation, and brake operation.
- f. Install new caster (with pull ring to out- side)

with 3/4-inch socket and socket wrench.

- g. Lower cage to ground level. Remove pallet jack or forklift.

2-2. CASTER LUBRICATION

- a. Lock caster brakes to prevent rolling of cage during lubrication.

NOTE

Some casters are supplied with only two grease fittings.

- b. Using a standard lubricating gun, lubricate each of the three grease fittings on each caster with grease.

2-3. CASTER BRAKE ADJUSTMENT (FIG. 2-1)

NOTE

Contents do not have to be removed for this operation.

- 2-3.1. **Inspection Procedures.** The following procedures are used to check the brake adjustment on the two front casters.

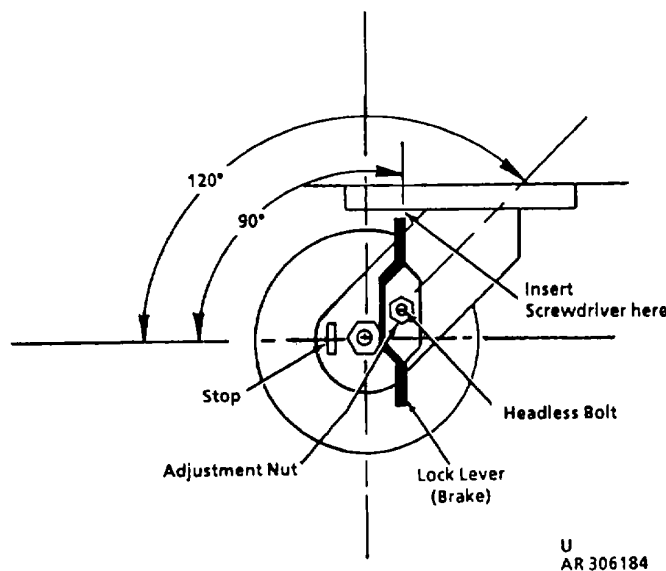

U
AR 306184

Figure 2-1. Caster Lock Lever (Brake) Adjustment

- a. Raise corner of cage using a pallet jack or fork lift until the caster wheel is approximately 3 to 6 inches from the floor. Place dunnage to secure this position.
- b. Rotate the brake lever clockwise by hand until the wheel is locked and it cannot be turned by hand. At this point the brake lever should be at least 90 degrees (to a vertical position) but no more than 120 degrees (parallel to the slope of caster leg) from its starting position against the stop. If the lever position is less than 90 degrees or greater than 120 degrees, readjust the brake using par. 2-3.2.

2-3.2. ADJUSTMENT PROCEDURES

- a. Using a 3/4 inch open end or box wrench and a large flat blade screwdriver to hold the bolt, loosen the brake lever adjustment nut until the nut is loose enough for the brake lever to turn freely on the bolt threads.

NOTE

The brake lever must be rotated to UNLOCK position (full counterclockwise) and against stop and held in position when turning bolt in procedure below.

- b. While one person turns wheel (by hand), another person using the screwdriver turns the bolt clockwise until resistance (friction) is felt on the wheel being turned.
- c. Position the brake lever in the vertical position (90 degrees from the stop) and retighten the nut using a 3/4-inch socket and torque wrench. Tighten to 470 ± 10 inch-pounds (39 ± 5 foot-pounds). Insert the screwdriver into the area

shown in figure 2-1, while tightening nut.

- d. After tightening nut, operate the lever three times to assure it is positioned properly (between 90 and 120 degrees from stop).
- e. Lower cage corner and repeat procedures for other front caster, if necessary.

2-4. REMOVING/INSTALLING CASTER SHOULDER BOLT PROCEDURES

- a. Remove caster in accordance with paragraph 2-1a thru 2-1d.
- b. Using a hammer, drive defective bolt upward until free front its mounting plate. Reach into access hole from below and remove defective bolt.

NOTE

The shoulder bolt will be seated after caster is reinstalled and fully tightened.

- c. After removing bolt, inspect mounting surface and mounting hole of the plate to be sure that they are free of dirt, rust or other foreign material and clean as required.
- d. Insert replacement bolt from top of plate into hole. Assure that bolt's ribbed portion enters the hole by holding thread end and pulling downward while rotating bolt.
- e. Install caster in accordance with paragraph 2-e thru 2-1g. Continue tightening caster hex nut on replaced shoulder bolt until bolt is fully seated. Check to see that bolt is seated by feeling that the shoulder rests against the top plate.

2-5. HINGE LUBRICATION

- a. Lock all caster brakes to prevent rolling of container while applying lubricant.
- b. Open cage (par. 1-6).
- c. Contents of cage should be covered with a throw cloth to protect them (removal of contents is optional method).
- d. Place a throw cloth in cage below hinge to absorb excess oil droplets.
- e. Using pump oiler; apply coating of lubricating oil to each of the horizontal slots in underside of hinge (fig. 2-2). Slots run parallel to hinge pin.

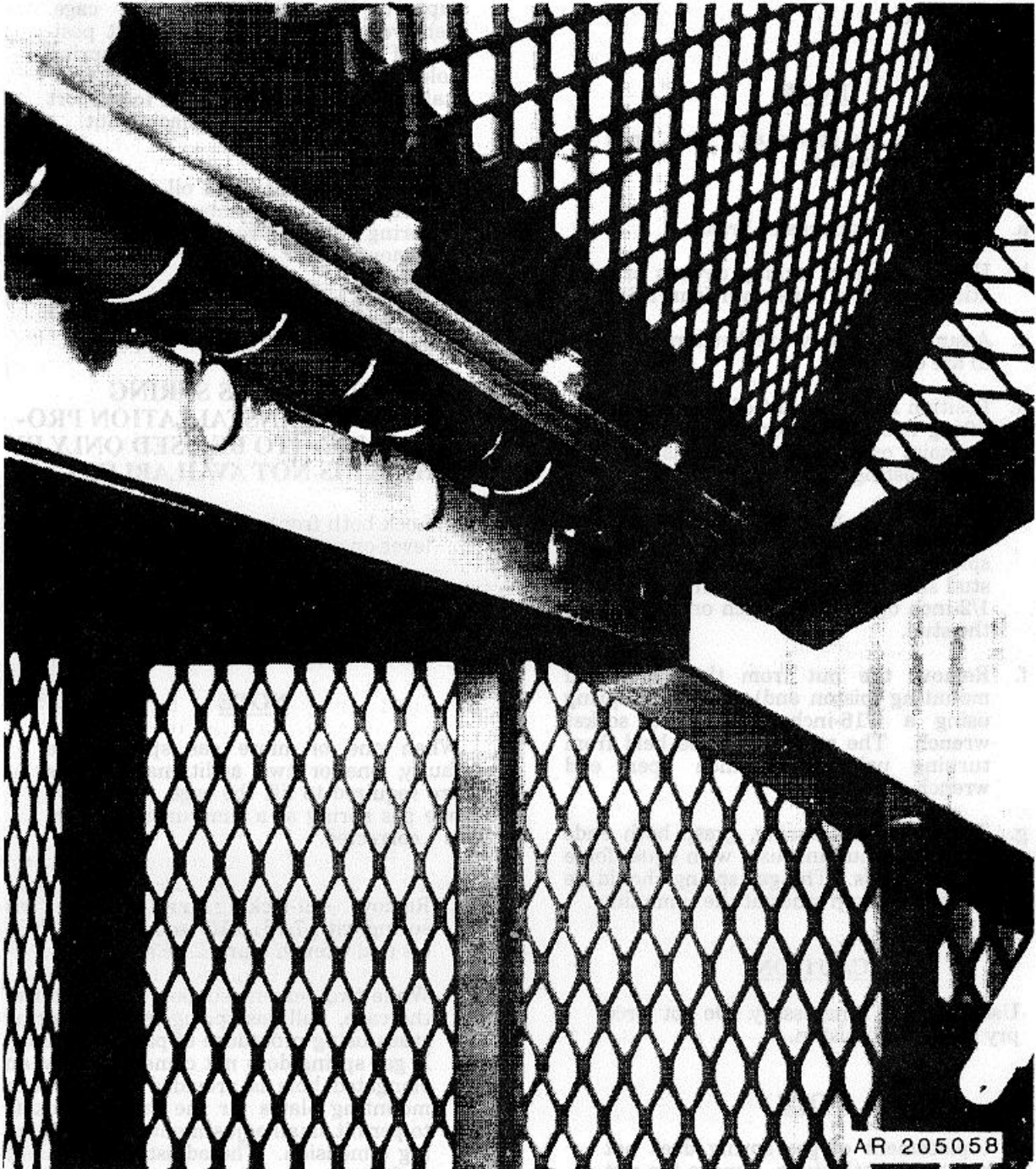

Figure 2-2. Hinge and Mounting from Underside of cage.

- f. With two persons, release safety bracket struts (2) by removing quick release pins.
- g. Raise and lower container cover 10 times.
- h. Wait 5 minutes and remove throw cloth(s).
- i. If removed, cage contents may be reinstalled. Close and lock container (par. 1-7).

Section II. GAS SPRINGS

2-6. REMOVING/INSTALLING GAS SPRING

NOTE

Remove one gas spring at a time until problem is corrected.

- a. Lock both front caster brakes.
- b. Unlock the two locking devices or variations and open cage cover (par. 1-6).
- c. Assure that safety bracket struts (fig. 1-5) are engaged.
- d. Position hoist in front of cage and attach lifting hook to center of cage. Take up on hoist only until: all slack is removed from hoisting line or chain.
- e. Remove the nut from the upper end mounting (cylinder end) of the gas spring using a 7/16-inch wrench. The stud should be held from turning using a 1/2-inch open-end wrench on the flats of the stud.
- f. Remove the nut from the lower end mounting (piston end) of the gas spring using a 9/16-inch socket and socket wrench. The stud should be held from turning using a 1/2-inch open end wrench on stud flats.
- g. To remove gas spring, grasp both ends and pull simultaneously with equal force on both ends. The gas spring should be freed from both studs at the same time.

CAUTION

Use a pry bar if necessary. Do not force pry bar against piston.

NOTE

If replacement of gas spring does not line up with both studs, remove top nut on the support strut while two persons support the weight of the cage. Remove support strut and

adjust position of cage until studs and gas spring holes align. Install gas spring and reinstall support strut. Apply oil to support strut and stud before replacing nut.

- h. Apply light coating of oil to surface and threads of both studs. Install new gas spring following reverse procedures from removal.
- i. Remove hoist.
- j. Close cage (par. 1-7).

2-7. ALTERNATE GAS SPRING REMOVAL/ INSTALLATION PROCEDURE. (TO BE USED ONLY IF HOIST IS NOT AVAILABLE.)

- a. Lock both front casters by turning brake lever on casters clockwise.
- b. Unlock two locking devices, raise front of cage, and secure brackets (par. 1-6).
- c. Assure safety brackets are engaged.

NOTE

When one or more gas springs are faulty, one or two additional persons are required to lift the cage. Remove one gas spring at a time until problem is corrected.

- d. Remove self-locking nuts holding gas spring with 7/16, 9/16, and 1/2-inch sockets and wrench (pars. 2-6e and 2-6f).
- e. While two persons support the weight of the cage, pull gas spring from mounting studs using procedure of paragraph 2-6g. If gas spring does not come off easily, an elongated hole is provided in the lower mounting plates for the safety brackets to permit small adjustment in WSC opening dimension. The adjustment is made as follows:

- (1) At the lower end of the safety bracket (strut), loosen the nut located between the mounting plate and the steel mesh side of the WSC with a 3/4-inch wrench. A thin wall (wrench thickness) 1/2-inch open-end wrench should be used to hold the stud between the mounting plate and the lower safety bracket strut. Do not remove the nut.
- (2) Adjust cage cover position until gas spring slides off mounting studs. Immediately retighten the lower nut on the stud.
- f. Apply a light coating of oil to surface and threads of both studs.
- g. Install new gas spring following reverse procedures from removal.

Section III. LOCKING DEVICE/ALTERNATE LOCKS

2-8. DESCRIPTION

2-8.1. The locking device (fig. 2-3) is a cylindrical lock consisting of three code wheels, a rectangular bolt, and a protective cover. The lock is not intended to be a high security lock.

2-8.2. Each code wheel has 11 letters and a diamond symbol. Rotating code wheels to the correct 3-letter code and pulling knob to the left opens the lock.

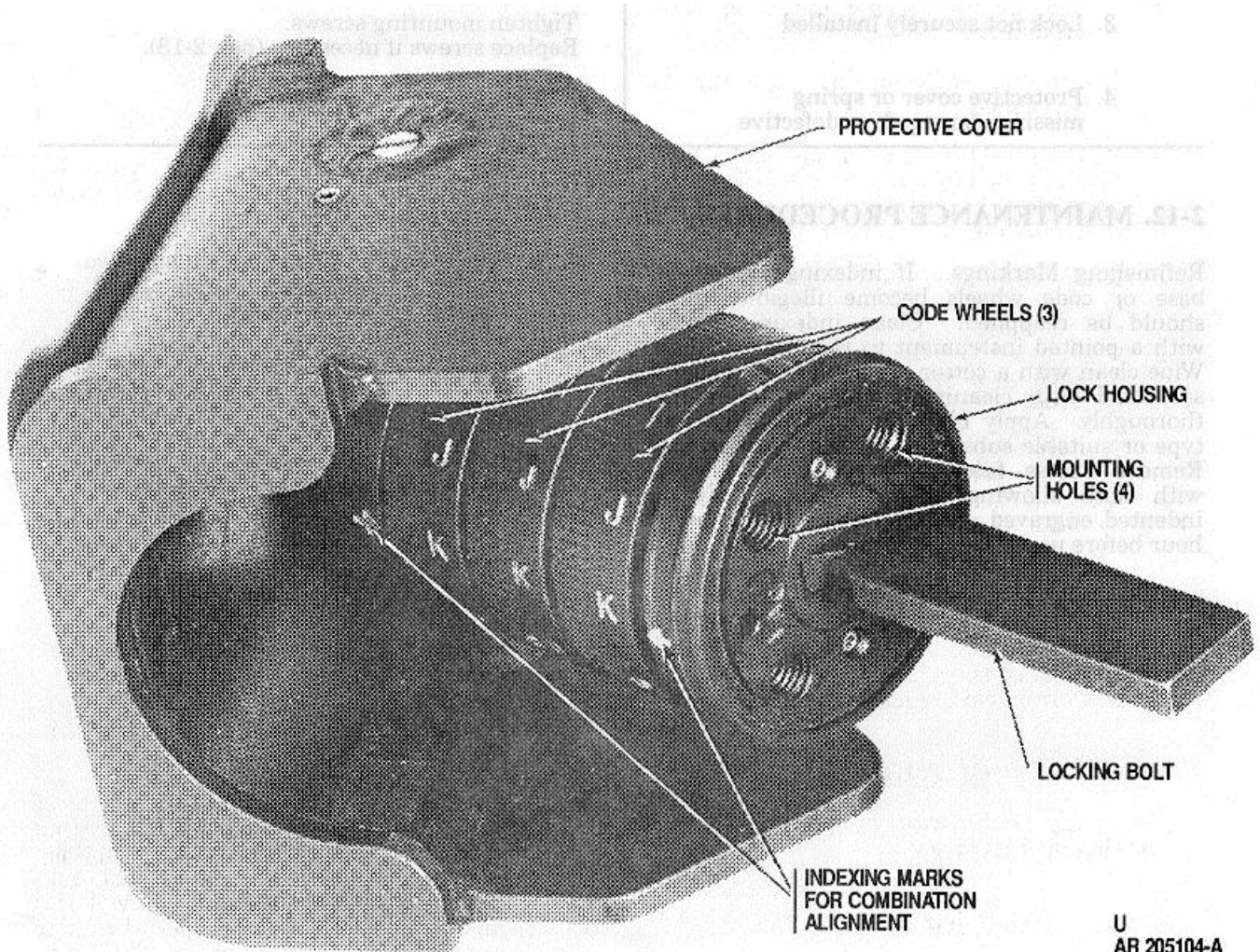

U
AR 205104-A

Figure 2-3. Locking Device with Protective Cover Rotated.

2-9. UNLOCKING

Unlock in accordance with paragraph 1-6a(1) thru (4).

2-10. LOCKING

Lock in accordance with paragraph 1-8a. thru f.

2-11. INSPECTION

Table 2-1 provides semi-annual inspection criteria and actions to be taken whenever defects are noted on lock.

TABLE 2-1.
SEMI-ANNUAL INSPECTION OF LOCKING DEVICE

INSPECTION	ACTION TO BE TAKEN
1. Code wheels do not rotate easily	Replace lock (par. 2-13).
2. Markings illegible	See paragraph 2-12.
3. Lock not securely installed	Tighten mounting screws.
4. Protective cover or spring missing, damaged, or defective	Replace screws if necessary (par. 2-13). Replace lock (par. 2-13).

2-12. MAINTENANCE PROCEDURES

Refinishing Markings. If indexing marks on base or code wheels become illegible, filler should be reapplied. Clean indexing marks with a pointed instrument to remove old filler. Wipe clean with a cotton-tip applicator or cloth saturated with cleaning compound, then dry thoroughly. Apply black opaque filler, crayon type or suitable substitute to engraved surface. Remove excess filler from adjoining surface with cloth allowing filler to remain only in indented engraved surface. Allow to air dry 1 hour before use of locking device.

NOTE

- WSC's are initially supplied with two locking devices unmounted. Procedure below covers installation of combination lock. Follow reverse procedure when removing locking device.
- It is recommended that two persons be used to replace the locking device.

**2-13. LOCKING DEVICE
INSTALLATION/REMOVAL**

- a. Lock installation requires a 5/16-inch allen wrench socket, 1/4-inch allen wrench socket, and flashlight.
- b. Raise cover of cage (par. 1-6).
- c. Record the three-letter combination that is stamped on the mounting face of the lock with serial number of cage. Also, record combination for either A or B mounting face of cage. Verify combination by unlocking lock (par. 1-6a).
- d. Align lock with mounting holes on left side of tang receptacle (fig. 2-4) by locating bolt (shackle) in rectangular hole of receptacle and alignment pin of lock in its mating hole. After bolt and pin are aligned, push lock against receptacle and hold in place with one hand.
- e. Install cap screw (No. 1 fig. 2-4) in hole at forward, right side of tang receptacle. Thread approximately two turns into lock using a 5/16-inch allen wrench.
- f. Install second cap screw (No. 2 fig. 2-4) in hole at forward, right side of tang receptacle. Thread approximately two turns into lock using a 5/16-inch allen wrench.
- g. Install one shoulder screw and spring (No. 3 fig. 2-4) in hole at rear, right side of tang receptacle. Use 1/4-inch allen wrench. Thread screw approximately two turns into lock with allen wrench by simultaneously compressing spring while turning.
- h. Install second shoulder screw and spring (No. 4 fig. 2-4) in hole at rear, right side of tang. Use 1/4-inch allen wrench and flat face screwdriver. Thread screw approximately two turns into lock with Allen wrench receptacle by simultaneously compressing spring while turning.
- i. Secure all four screws to complete lock installation.
- j. Close and secure cage (par. 1-7).
- k. To remove locking device, open cage and loosen the four screws and withdraw lock in reverse order (pars. d through i).

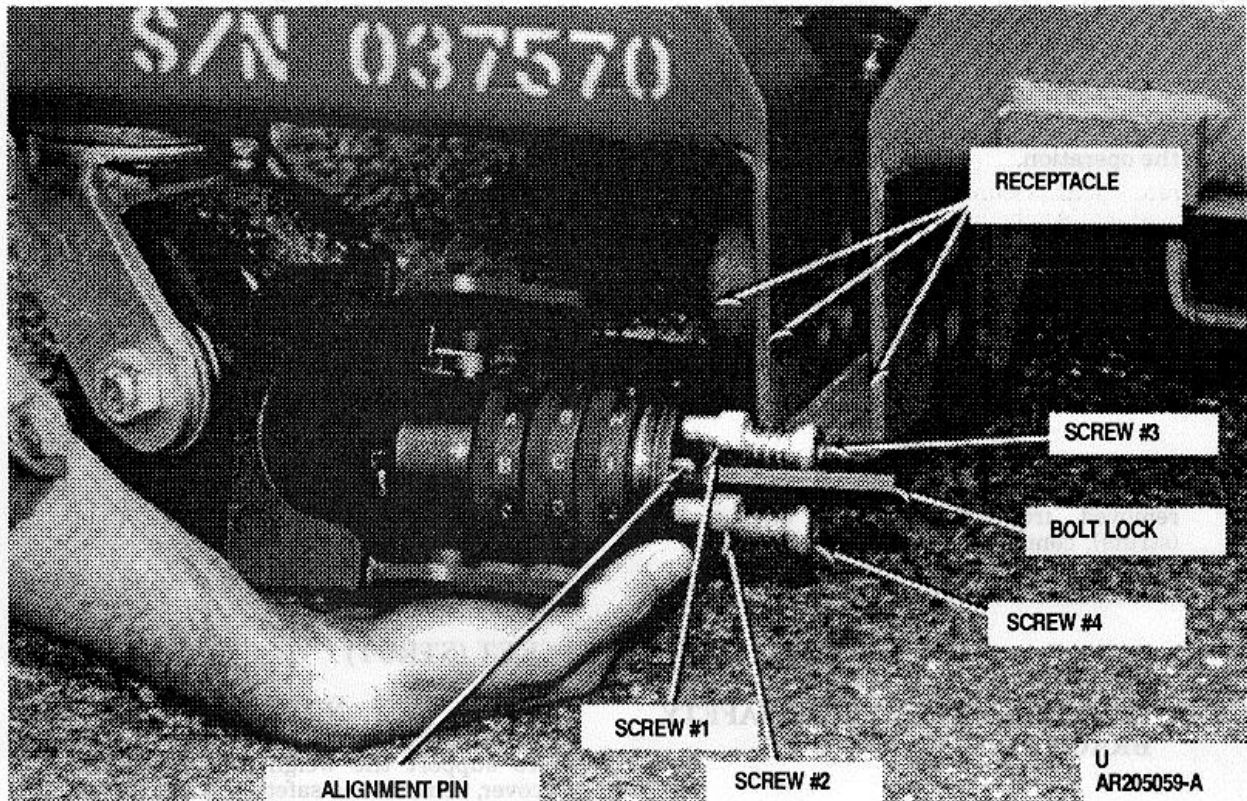

Figure 2-4. Installing Locking Devices.

Section IV. REPLACING/INSTALLING CATCH

2-14. PROCEDURES

NOTE

Contents do not have to be removed for the operation.

- a. Open WSC in accordance with para- graph 1-6a (1) thru (4).
- b. Using a 7/16-inch socket and socket wrench, remove the two 1/4-20 cap screws securing the catch to the exterior (bottom T-section) surface of the cage. It will be necessary to hold the two 1/4-20 self locking nuts at the back of the T-section with a 7/16 inch wrench. Remove the catch.
- c. Aline new catch holes with the two through holes on the exterior (bottom T-section) surface of the cage.
- d. Install two 1/4-inch-20 x 1-inch long head cap screws into both holes of the catch and the cage.
- e. Fasten cap screws in place using two 1/4-20 self-locking nuts. Tighten with the 7/16-inch wrench.
- f. Catch adjustment can be performed by screwing the catching screw either in or out until proper snugness of the catch is obtained.

Section V. REMOVING/INSTALLING QUICK RELEASE PIN AND CHAIN ASSEMBLY

2-15. PROCEDURES

NOTE

Contents do not have to be removed for the operation.

- a. Lock both front caster brakes.
- b. Open WSC in accordance with para- graph 1-6a (1) thru (4)
- c. Using a No. 1 phillips head screwdriver, remove self-locking screw which fastens bead chain assembly to safety bracket (strut).
- d. Unpackage and prepare new quick release pin and bead chain assembly for installation.
- e. Remove quick release pin from safety bracket (strut) and immediately insert new quick release pin in bracket hole. Let bead chain assembly hang loose temporarily.
- f. Inspect threads and locking element of self-locking screw. If damaged, replace with new screw. Inspect threads in safety bracket (strut) hole; if damaged, replace safety bracket (strut).
- g. Using screwdriver, fasten end of bead chain assembly to safety bracket with the self-locking screw. Tighten the screw securely.
- h. Close cage.

NOTE

If the quick release pins are to be removed from both safety bracket (struts), complete removal and installation of the release pin on one safety bracket (strut) at a time.

Section VI. SAFETY BRACKET (STRUT)

2-16. REMOVING/INSTALLING SAFETY BRACKET (STRUT)

NOTE

To support the weight of the opened cover, remove one safety bracket (strut) at a time.

- a. Lock both front caster brakes.
- b. Unlock the two locking devices and open cage cover (par. 1-6).
- c. Assure that safety bracket (struts) (fig. 1-5) are engaged.
- d. Position hoist in front of cage and attach lifting hook to center of cage cover front edge. Take up on hoist only until all slack is removed from hoisting line or chain. (An alternative method is to use two persons to support opened cover during replacement of the safety bracket strut.)
- e. Remove nut from lower end of safety bracket (strut) using a 9/16-inch socket and socket wrench (or 9/16-inch wrench). It may be necessary to hold the nut at the other end of the stud with a 3/4-inch open-end wrench. If a thin-wall (wrench thickness) 1/2-inch open-end wrench is available, hold stud between the bracket and side wall of cage instead of the 3/4-inch nut.
- f. Remove nut from upper end of safety bracket (strut) with the same tools as e. above. Hold the 1/2-inch flat on the stud between the bracket and the side wall of cage with a 1/2-inch open-end wrench.
- g. While supporting the weight of the cage cover, pull safety bracket (strut) from its upper and lower mounting studs.
- h. Apply a light coating of oil to surface threads of both mounting studs. Install new safety bracket (struts) following reverse procedures from

removal. It may be necessary to apply pressure to cover top either up or down to align safety bracket hole with stud.

- i. Close cage.

2-17. REPAIR OF SAFETY BRACKET (STRUT) ASSEMBLY

If any part of the safety bracket strut assembly other than the chain and quick release pin assembly is damaged, part or parts can be replaced in accordance with the following repair procedures. (Replacement of the chain and quick release pin assembly is described in paragraph 2-15).

- a. Remove damaged safety bracket strut (par. 2-16).
- b. Using pliers, remove cotter pin from the straight-headed pin which serves as a hinge pin for two strut weldments.
- c. Holding safety bracket (strut) assembly, remove straight pin securing two strut weldments.
- d. Remove the two flat washers.
- e. Holding replacement to damaged part in place, insert straight pin through strut weldments and flat washers.
- f. Install a new cotter pin in hole in straight pin to keep pin in place.
- g. Replace safety bracket strut assembly on weapon security container (par. 2-16).

THIS PAGE INTENTIONALLY LEFT BLANK

CHAPTER 3

WEAPON SECURITY CAGE VARIATIONS IN USE

3-1. GENERAL

The weapon security cage (WSC) is issued to a user in a standard configuration with standard locking and internal application features. The user has several options to consider for the varied uses of a WSC and possible applications in the future. The options are the type of locking mechanism employed and the internal parameters desired by the user.

3-2. LOCKING APPLICATIONS

Alternate locking procedures employing a security padlock can be used. A reversible modification to the WSC is necessary and will not alter the WSC's outside configuration. The conversion kit can be applied to the WSC in the following manner.

NOTE

Screwdriver type allen wrenches are recommended.

3-2.1. Padlock Bracket Kit Installation/Removal Procedures

- a. Lock installation requires a 5/16-inch allen wrench socket/driver, a 1/4-inch allen wrench socket/driver, a 3/32-inch allen wrench ball/driver, and a flashlight.

The bracket kit contains 2 metal fittings and a 6-32-inch screw.

- b. Raise cage cover (par. 1-6).
- c. Remove bracket from its packaging kit.

NOTE

Cap screws and shoulder screws and springs are used for either issued locking device or padlock application.

- d. Install cap screw (fig. 3-1) in hole at forward, right side of tang receptacle. Thread approximately two turns into bracket using a 5/16-inch allen wrench.
- e. Install second cap screw (fig. 3-1) in hole at forward, right side of tang receptacle. Thread approximately two turns into bracket using a 5/16-inch allen wrench.
- f. Install one shoulder screw and spring (fig. 3-1) in hole at right side of tang receptacle. Using a 1/4-inch allen wrench, thread screw approximately two turns into bracket while applying pressure to screw and spring.
- g. Install second shoulder screw and spring (fig. 3-1) in hole at rear, right side of receptacle. Using a 1/4-inch allen wrench, thread screw approximately two turns into bracket while applying pressure to screw and spring.

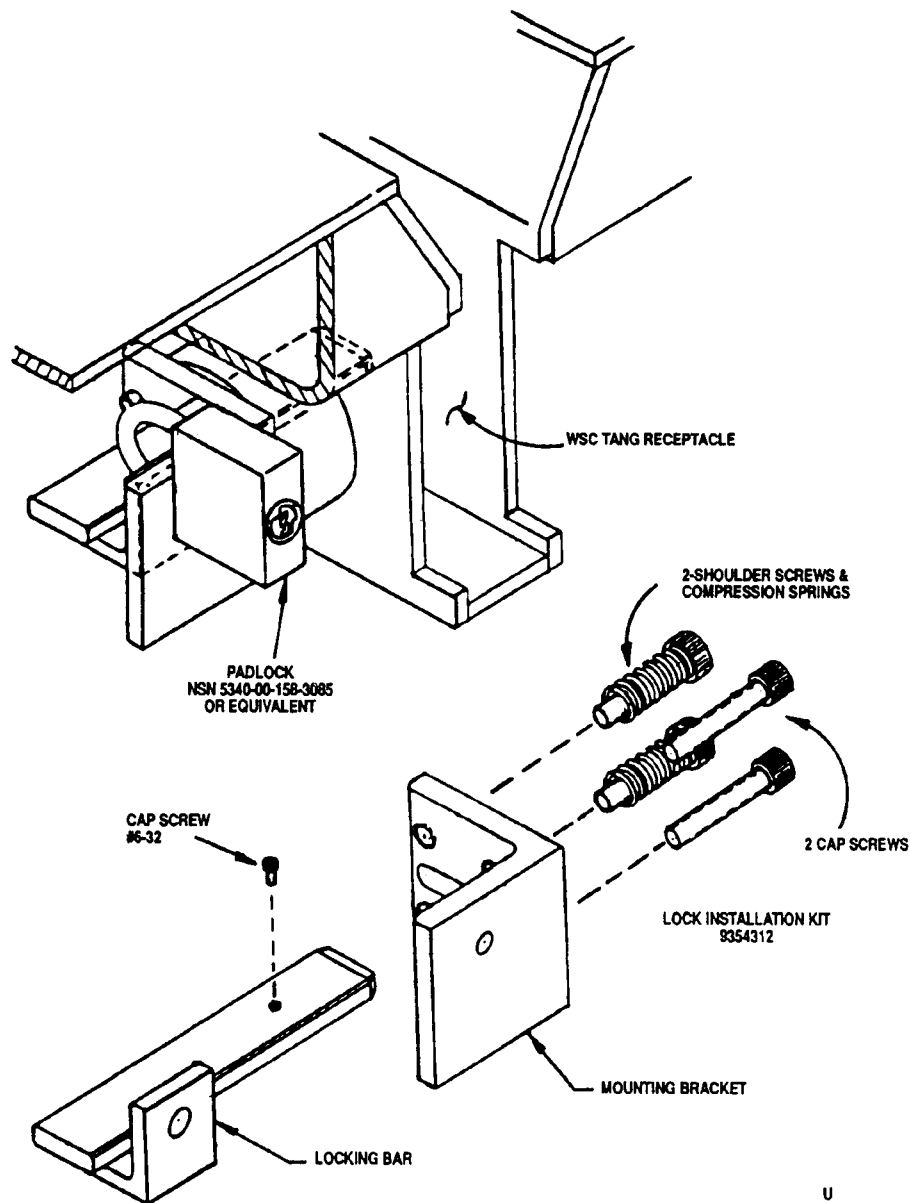

U
AR307184

Figure 3-1. Alternate Lock Configuration for Weapon Security Cage, XH4289.

- h. Tighten all four screws beginning with the shoulder screws and springs.
- i. Insert locking bar through bracket and tang receptacle. Ensure padlock holes align. Within tang receptacle, install a 6-32 cap screw into locking bar using a 3/32-inch allen wrench ball driver.
- j. Close and secure cage with padlocks.

- k. To return WSC to original configuration, raise cover and remove the five screws beginning with the 6-32 cap screws.

3-3. INTERNAL CONFIGURATION OF WSC

Due to the original design of the WSC, the as issued WSC provides an open rectangular area (internal area) approximately 70 x 61 x 28 inches, but is modified to accept various clamps and tiedowns for special storage. Changes and applications to the internal base of the WSC (fig. 3-2) are based on the individual usage needs and any special clamping or tiedown can be done. Clamps and straps can be attached to fixtures. The clamp application can be used to hold a container in place. The strap application when used with tiedowns and an extension bar/ratchet, provides securing to flat surface.

NOTE
Process is fully reversible and WSC can be returned to original configuration.

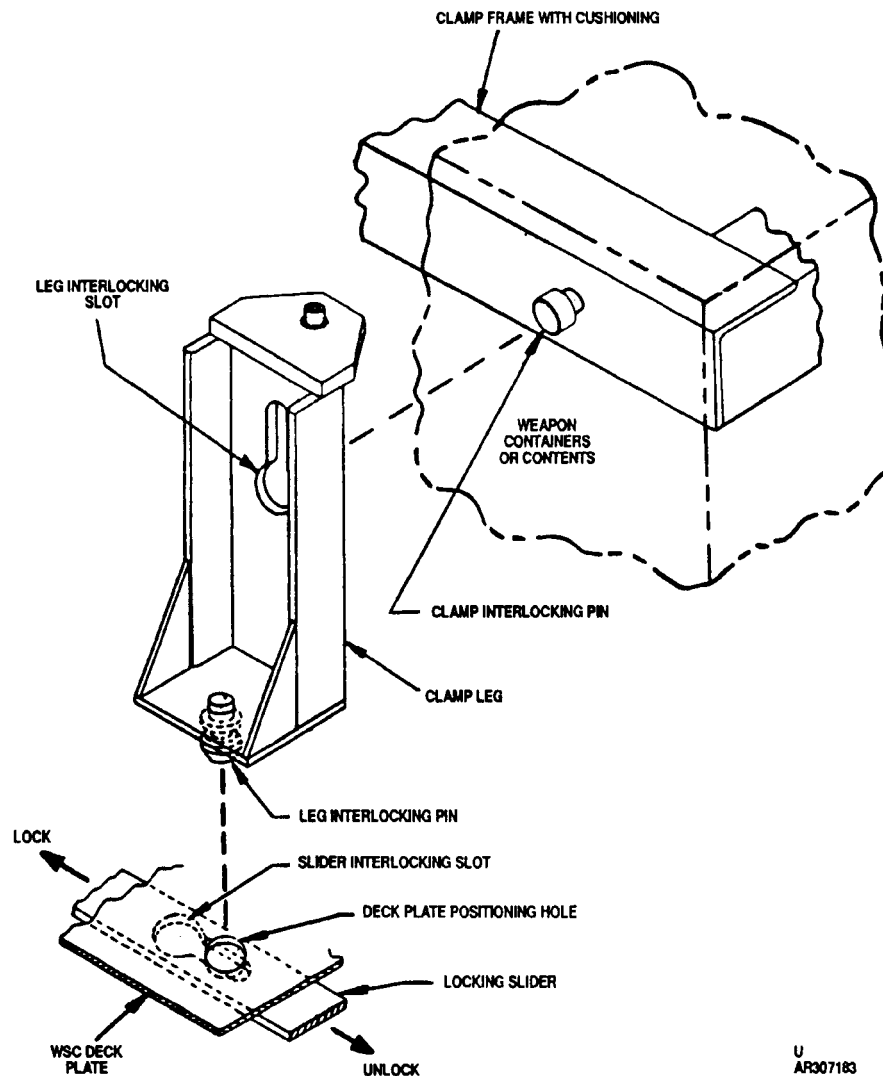

U
 AR307183

Figure 3-2. Clamping Configuration for Contents Stored in Weapon Security Cage XH4289.

THIS PAGE INTENTIONALLY LEFT BLANK

**APPENDIX A
GENERAL MAINTENANCE PROCEDURES**

A1-1. GENERAL

A1-1.1. Variations of standard maintenance methods, or a combination of methods, outlined in this section may be required under certain circumstances. Such variations or combinations may be used as required, depending on materials available, degrees of disassembly, time element, military situation, or personnel safety factor.

A1-1.2. Organizations authorized overhead hoists may use them where necessary (or helpful) to perform operations in this manual.

A1-1.3. Components specified herein will be touched-up, including markings as required, using paint of the same color as original equipment as issued or on hand. However, the shade of the touch-up paint need not be the exact shade of original material.

A1-2. EXPENDABLE MATERIALS

Expendable materials authorized for painting, cleaning, preserving, and other maintenance-related operations for components are listed in this appendix. However, list should not be considered as furnishing a mandatory stockage list or anything similar. Units should only requisition expendables insofar as they are able to receive, store, maintain, and utilize same.

A1-3. LUBRICATION

Lubrication procedures, if required, are given in the paragraphs for specific components. Other than stated in these paragraphs, lubrication is not authorized.

A1-4. CLEANING

- a. Remove foreign material such as rust and corrosion from metal surfaces by using abrasive paper or wire brush. Prevent particles from entering exposed openings (tie-down holes and openings in steel box sections in cages or bolt holes in the security locking devices). Wipe surfaces with a clean cloth moistened with cleaning compound.
- b. Remove foreign material such as grease or oil from unpainted surfaces using a clean cloth moistened with cleaning compound.
- c. Remove foreign material such as mud, salt, water, grease, or oil from painted, marked surfaces or rubber with a clean cloth moistened with detergent and water. Avoid trapping detergent and water in interior areas.

d. Remove fungus growth as follows:

- (1) Prepare a solution of alcohol and water (60 to 70 percent alcohol).
- (2) Wipe fungus-affected areas with a clean cloth moistened with alcohol and water solution.
- (3) Inspect painted surfaces. If damage to paint has resulted from fungus growth, paint in accordance with procedures in paragraph A1-5.

A1-5. PAINTING**NOTE**

The following procedures are for area stripped to base material. If an item or area has intermediate preservation coats exposed, only those procedures necessary to complete the method need be applied.

- a. Remove corrosion from metal surfaces by sanding with medium grade abrasive (aluminum oxide, 100 grit or equivalent). A wire brush may also be used.
- b. Clean surface with FREON, MIL-C-81302, and allow to dry.
- c. When repainting, apply two coats of primer (TT-P-664). Allow at least 25 minutes air-dry time between coats. Apply one or two coats of enamel (MIL-E-15090) gray (recommended, but not required). Allow at least 2 hours air-dry time per coat.
- d. For items painted with chemical agent resistant coating (CARC) refer to the appropriate weapon systems organizational maintenance manual for painting and marking touch up procedures and to the appropriate general support maintenance manual for procedures on complete repainting and remarking.

A1-6. MARKING

NOTE

When CARC has been applied to the WSC, the letters "CARC" will be marked where indicated on figure A1-1, to the right of the ID plate.

Marking for the WSC shall be in accordance with figure A1-1. Touch up worn or illegible markings as necessary, using existing colors and materials. After complete repainting with CARC, use CARC (MIL-C-46168 or MIL-C-53039) black 37030, or 37038 for all markings where white was used previously.

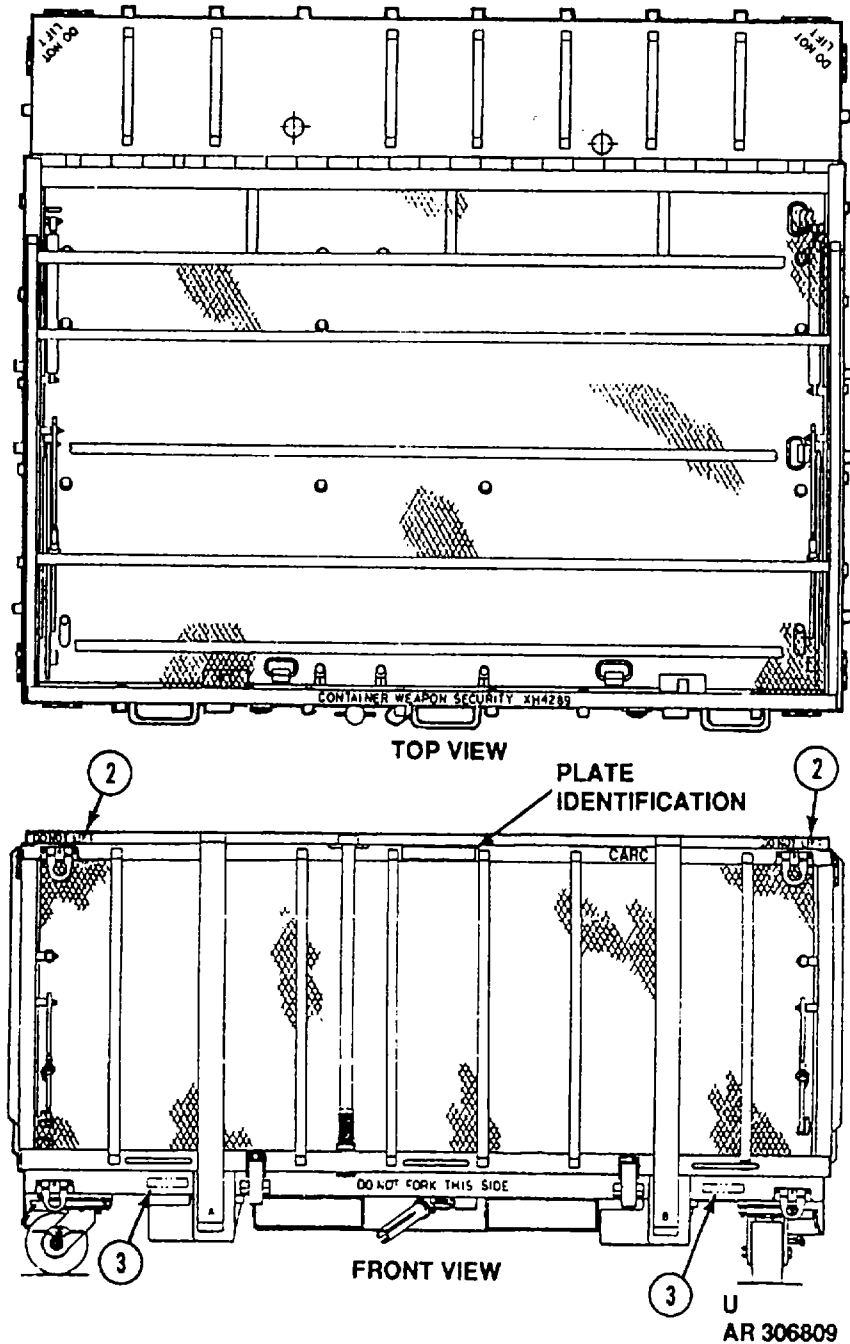
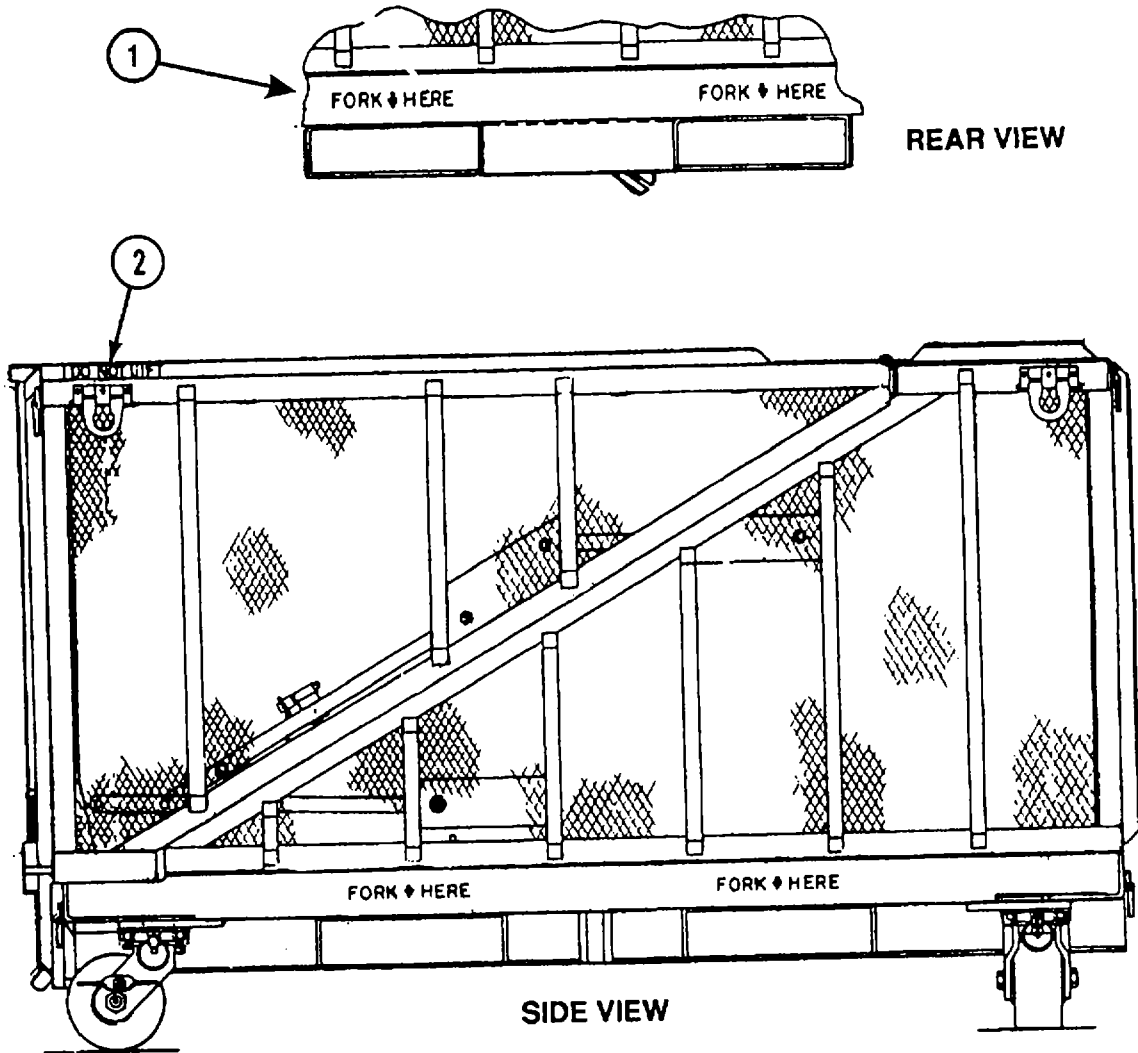

Figure A1-1. Weapon Security Cage Marking (Part 1 of 2).



MARKING INSTRUCTIONS

- ① ALL MARKINGS WILL BE 3/4 INCH HIGH, EXCEPT AS NOTED.
- ② MARKINGS WILL BE 1/2 INCH HIGH.
- ③ SERIAL NUMBER OF WEAPON SECURITY CONTAINER.

U
AR306810-A

Figure A1-1. Weapon Security Cage Marking (Part 2 of 2).

THIS PAGE INTENTIONALLY LEFT BLANK

A-4

APPENDIX B

OPERATOR, UNIT, DIRECT SUPPORT AND GENERAL SUPPORT

REPAIR PARTS AND SPECIAL TOOLS LIST

(INCLUDING DEPOT MAINTENANCE REPAIR PARTS AND SPECIAL TOOLS)

SECTION I. INTRODUCTION

B-1. Scope.

This RPSTL lists and authorizes spares and repair parts; special tools; special test, measurement, and diagnostic equipment (TMDE); and other special support equipment required for performance of operator, unit, direct support and general support maintenance including depot maintenance of the Weapon Security Cage (WSC). It authorizes the requisitioning, issue, and disposition of spares, repair parts and special tools as indicated by the source, maintenance and recoverability (SMR) codes.

B-2. General.

In addition to Section I, Introduction, this Repair Parts and Special Tools List is divided into the following sections:

a. Section II - Repair Parts List. A list of spares and repair parts authorized by this RPSTL for use in the performance of maintenance. The list also includes parts which must be removed for replacement of the authorized parts. Parts lists are composed of functional groups in ascending alphanumeric sequence, with the parts in each group listed in ascending figure and item number sequence. Bulk materials are listed by item name in FIG. BULK at the end of the section. Repair parts kits or sets are also listed separately in their own functional group within Section II. Repair parts for repairable special tools are also listed in this section. Items listed are shown on the associated illustration.

b. Section III - Special Tools List. Not required.

c. Section IV - Cross-reference Indexes. There are three cross-reference indexes in the RPSTL: A National Stock Number Index in National item identification number (NTIN) sequence and a Part Number Index in alphanumeric sequence and a Figure and item number index that list figure and item number in alphanumeric sequence and cross-references NSN, CAGEC and part number.

B-3. Explanation of Columns (Sections II).

a. ITEM NO. (Column (1)). Indicates the number used to identify items called out in the illustration.

b. SMR CODE (Column (2)). The Source, Maintenance, and Recoverability (SMR) code is a 5-position code containing supply/requisitioning information, maintenance category authorization criteria, and disposition instructions, as shown in the following breakout:

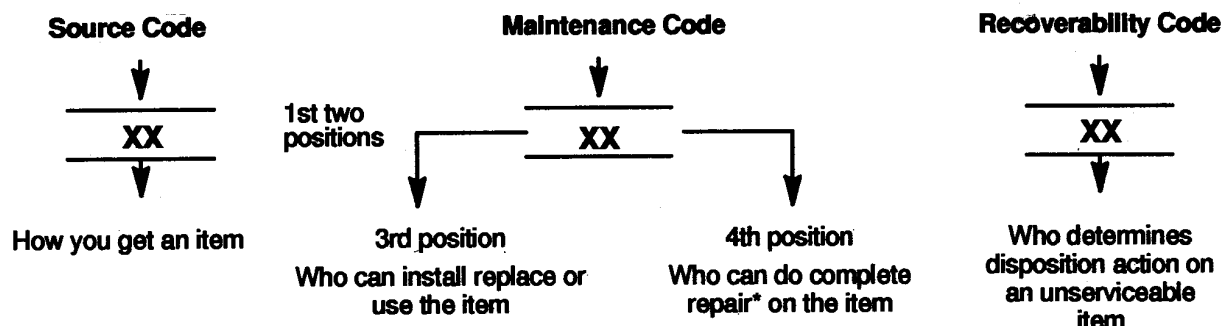

*Complete Repair: Maintenance capacity, capability, and authority to perform all corrective maintenance tasks of the "Repair" function in a use/user environment in order to restore serviceability to a failed item.

(1) Source Code. The source code tells you how you get an item needed for maintenance, repair, or overhaul of an end item/equipment. Source codes are always the first two positions of the SMR Code. Explanations of source codes follow:

Code	Explanation
PA PB PC** PD PE PF PG	<p>Stocked items; use the applicable NSN to request/requisition items with these source codes. They are authorized to the category indicated by the code entered in the 3rd position of the SMR code.</p> <p>**NOTE : Items coded PC are subject to deterioration.</p>
KD KF KB	<p>Items with these codes are not to be requested/requisitioned individually. They are part of a kit which is authorized to the maintenance category indicated in the 3rd position of the SMR code. The complete kit must be requisitioned and applied.</p>
MO (Made at org AVUM level) MF (Made at DS/AVUM level) MH (Made at GS level) ML (Made at Specialized Repair Activity (SRA)) MD (Made at Depot)	<p>Items with these codes are not to be requested/requisitioned individually. They must be made from bulk material which is identified by the part number in the DESCRIPTION and USABLE ON CODE (UOC) column and listed in the Bulk Material group of the repair parts list in the RPSTL. If the item is authorized to you by the 3rd position code of the SMR code, but the source code indicates it is made at a higher level, order the item from the higher level of maintenance.</p>

- AO (Assembled by org AVUM Level)
- AF (Assembled by DS/AVUM Level)
- AH (Assembled by GS Category)
- AL (Assembled by SRA)
- AD (Assembled by Depot)



Items with these codes are not to be requested/requisitioned individually. The parts that make up the assembled item must be requisitioned or fabricated and assembled at the level of maintenance indicated by the source code. If the 3rd position code of the SMR code, authorizes you to replace the item, but the source code indicates the items are assembled at a higher level, order the item from the higher level of maintenance.

- XA - - Do not requisition an "XA"-coded item. Order its next higher assembly. (Also, refer to the NOTE below.)
- XB - - If an "XB" item is not available from salvage, order it using the CAGE Code and part number given.
- XC - - Installation drawing, diagram, instruction sheet, field service drawing, that is identified by manufacturer's part number.
- XD - - Item is not stocked. Order an "XD"-coded item through normal supply channels using the CAGE Code and part number given, if no NSN is available.

NOTE

Cannibalization or controlled exchange, when authorized, may be used as a source of supply for items with the above source codes, except for those source coded "XA" or those aircraft support items restricted by requirements of AR 750-1

(2) Maintenance Code. Maintenance codes tell you the level(s) of maintenance authorized to USE and REPAIR support items. The maintenance codes are entered in the third and fourth positions of the SMR Code as follows:

(a) The maintenance code entered in the third position tells you the lowest maintenance level authorized to remove, replace, and use an item. The maintenance code entered in the third position will indicate authorization to one of the following levels of maintenance.

Code	Application/Explanation
C -	Crew or operator maintenance done within unit/AVUM maintenance.
O -	Unit level maintenance can remove, replace, and use the item.
F -	Direct support level maintenance can remove, replace, and use the item.
H -	General support maintenance can remove, replace, and use the item.
L -	Specialized repair activity can remove, replace, and use the item.
D -	Depot can remove, replace, and use the item.

(b) The maintenance code entered in the fourth position tells you whether or not the item is to be repaired and identifies the lowest maintenance level with the capability to do complete repair (i.e., perform all authorized repair functions). This position will contain one of the following maintenance codes.

NOTE

Some limited repair may be done on the item at a lower level of maintenance, if authorized by the Maintenance Allocation Chart (MAC) and SMR Codes.

Code	Application/Explanation
O -	Unit level maintenance can remove, replace, and use the item.
F -	Direct support level maintenance can remove, replace, and use the item.
H -	General support maintenance can remove, replace, and use the item.
L -	Specialized repair activity can remove, replace, and use the item.
D -	Depot can remove, replace, and use the item.
Z -	Nonreparable. No repair is authorized.
B -	No repair is authorized. No parts or special tools are authorized for the maintenance of a "B" coded item. However, the item may be reconditioned by adjusting, lubricating, etc., at the user level.

(3) Recoverability Code. Recoverability codes are assigned to items to indicate the disposition action on unserviceable items. The recoverability code is shown in the fifth position of the SMR Codes as follows:

Recoverability Codes	Application/Explanation
Z -	Nonreparable item. When unserviceable, condemn and dispose of the item at the level of maintenance shown in 3rd position of SMR Code.
O -	Reparable item. When not economically repairable, condemn and dispose of the item at unit level.
F -	Reparable item. When uneconomically repairable, condemn and dispose of the item at the direct support level.
H -	Reparable item. When uneconomically repairable, condemn and dispose of the item at the general support level.
D -	Reparable item. When beyond lower level repair capability, return to depot. Condemnation and disposal of item not authorized below depot level.
L -	Reparable item. Condemnation and disposal not authorized below specialized repair activity (SRA).

A - Item requires special handling or condemnation procedures because of specific reasons (e.g., precious metal content, high dollar value, critical material, or hazardous material). Refer to appropriate manuals/directives for specific instructions.

c. CAGEC (Column (3)). The commercial and government entity code (CAGEC) is a 5-digit numeric code used to identify the manufacturer, distributor, or Government agency/activity that supplies the item.

d. Part Number (Column (4)). Indicates the primary number used by the manufacturer (individual, company, firm, corporation, or Government activity), which controls the design and characteristics of the item by means of its engineering drawings, specifications, standards, and inspection requirements to identify an item or range of items.

NOTE

When you use a NSN to requisition an item, the item you receive may have a different part number from the part ordered.

e. Description and Usable On Code (UOC) (Column (5)). This column includes the following information:

- (1) The Federal item name, and when required, a minimum description to identify the item.
- (2) Items that are included in kits and sets are listed below the name of the kit or set.
- (3) Spare/repair parts that make up an assembled item are listed immediately following the assembled item line entry.
- (4) Part numbers for bulk materials are referenced in this column in the line item entry for the item to be manufactured/fabricated.
- (5) When the item is not used with all serial numbers of the same model, the effective serial numbers are shown on the last line(s) of the description (before UOC)
- (6) The usable on code, when applicable (see paragraph B5, Special Information).
- (7) The statement "END OF FIGURE" appears just below the last item description in Column (5) for a given figure in both Section II and III.

f. QTY (Column 6). The QTY (quantity per figure column) indicates the quantity of the item used in the breakout shown on the illustration figure, which is prepared for a functional group, subfunctional group, or an assembly. A "V" appearing in this column in lieu of a quantity indicates that the quantity is variable and the quantity may vary from application to application.

B-4. Explanation of Columns (Section IV).

a. NATIONAL STOCK NUMBER (NSN) INDEX.

(1) STOCK NUMBER column. This column lists the NSN by National item identification number (NIIN) sequence. The NIIN consists of the last 9 digits of the NSN.

NSN
 (i.e., 5305-01-574-1467)
NIIN

When using this column to locate an item, ignore the first 4 digits of the NSN. However, the complete NSN should be used when ordering items by stock number.

(2) FIG. column. This column lists the number of the figure where the item is identified/located. The figures are in numerical order in Section II and Section III.

(3) ITEM column. The item number identifies the item associated with the figure listed in the adjacent FIG. column. This item is also identified by the NSN listed on the same line.

b. PART NUMBER INDEX. Part numbers in this index are listed by part number in ascending alphanumeric sequence (vertical arrangement of letters and number combinations which place the first letter or digit of each group in order A through Z, followed by the numbers () through 9 and each following letter or digit in like order).

(1) CAGEC column. The Commercial and Government Entity Code (CAGEC) is a 5-digit numeric code used to identify the manufacturer, distributor, or Government agency/activity that supplies the item.

(2) PART NUMBER column. Indicates the primary number used by the manufacturer (individual, firm corporation, or Government activity) which controls the design and characteristics of the item by means of its engineering drawings, specifications, standards, and inspection requirements to identify an item or range of items.

(3) STOCK NUMBER column. This column lists the NSN for the associated part number and manufacturer identified in the PART NUMBER and CAGEC columns to the left.

(4) FIG. column. This column lists the number of the figure where the item is identified/located in Section II and III.

(5) ITEM column. The item number is that number assigned to the item as it appears in the figure referenced in the adjacent figure number column.

c. FIGURE AND ITEM NUMBER INDEX.

(1) FIG. column. This column lists the number of the figure where the item is identified/located in Section II and III.

(2) ITEM column. The item number is that number assigned to the item as it appears in the figure referenced in the adjacent figure number column.

(3) STOCK NUMBER column. This column lists the NSN for the item.

(4) CAGEC column. The commercial and government entity code is a 5-digit code which is used to identify the manufacturer, distributor, or government agency/activity that supplies the item.

(5) PART NUMBER. Indicates the primary number used by the manufacturer (individual, firm, corporation, or Government activity), which controls the design and characteristics of the item by means of its engineering drawings, specifications standards, and inspection requirements to identify an item or range of items.

B-5. Special Information.

a. USABLE ON CODE. The usable on code appears in the lower left corner of the Description column heading. Usable on codes are shown as "UOC....." in the Description column (justified left) on the first line applicable item description/nomenclature. Uncoded items are applicable to all models. Identification of the usable on codes used in the RPSTL are:

<u>Code</u>	<u>Used On</u>
WS2	Weapon Security Cage

b. ASSEMBLY INSTRUCTION. Detailed assembly instructions for items source coded to be assembled from component spare/repair parts are found in the narrative portion of this manual. Items that make up the assembly are listed immediately following the assembly item entry or reference is made to an applicable figure.

B-6. How to Locate Repair Parts.

a. When National Stock Number or Part Number is Not Known:

(1) First. Using the table of contents, determine the assembly group or subassembly group to which the item belongs. This is necessary since figures are prepared for assembly groups and subassembly groups, and listings are divided into the same groups.

(2) Second. Find the figure covering the assembly group or subassembly group to which the item belongs.

(3) Third. Identify the item on the figure and note the number(s).

(4) Fourth. Refer to the repair parts list for the figure to find the part number(s) noted on the figure.

b. When National Stock Number or Part Number is Known:

(1) First. Using the National Stock Number or the Part Number Index, find the pertinent National Stock Number or Part Number. The NSN index is arranged in National Item Identification Number (NIIN) sequence (See B-4.a(1)). The part numbers in the Part Number index are listed in ascending alphanumeric sequence (See B-4.b). Both indexes cross-reference you to the illustration/figure and item number of the item you are looking for.

(2) Second. Turn to the figure and locate the item number. Verify that the item is the one you are looking for.

B-7. Abbreviations.

CARC - Chemical Agent Resistant Coating
All others are common.

SECTION II
REPAIR PARTS

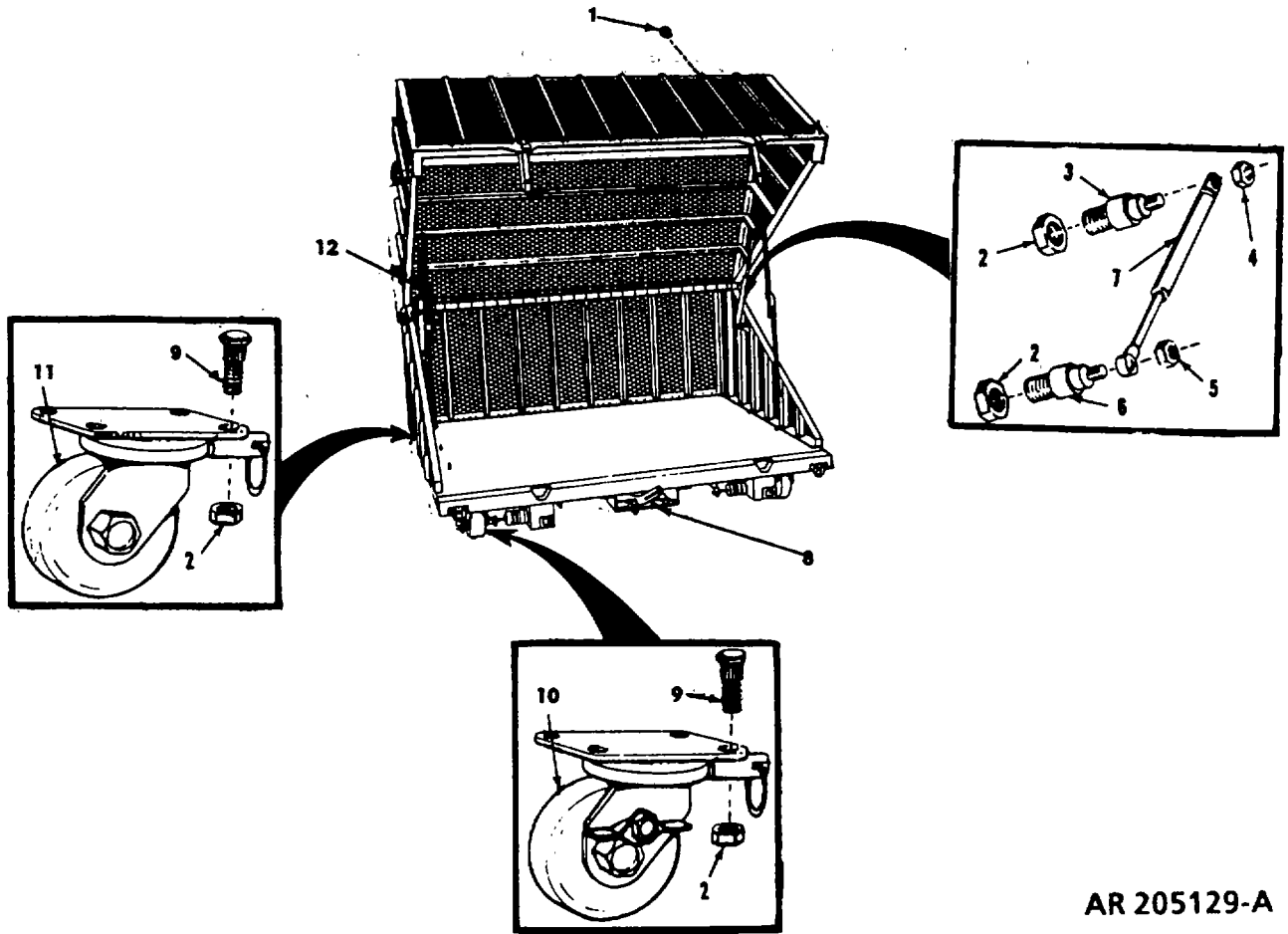

AR 205129-A

FIGURE B1. WEAPON SECURITY CAGE (Part 1 of 2)

(1) ITEM NO	(2) SMR CODE	(3) CAGEC	(4) PART NUMBER	(5) DESCRIPTION AND USABLE ON CODES(UOC)	(6) QTY
GROUP 01 WEAPON SECURITY CAGE 9349591 (19200)					
FIGURE B1 WEAPON SECURITY CAGE (PART 1 OF 2)					
1	PAOZZ	19200	9369995	PLUG, PROTECTIVE, DUST AND MOISTURE SEAL:	80
2	PAOZZ	96906	MS51943-40	NUT, SELF-LOCKING, HEXAGON: STL, CD-PLD, .5-20 UNF- 3B X .75 IN. WAF	4
3	PAOZZ	19200	9354364-1	STUD, SHOULDERED AND STEPPED:	2
4	PAOZZ	96906	MS51943-31	NUT, SELF-LOCKING, HEXAGON: STL, CD-PLD, .375-..... 16UNC-3B, X .551 IN. WAF SEE AR3()5752-A BREAKOUT DEPICTING NUT	6
5	PAOZZ	96906	MS51943-33	NUT, SELF-LOCKING, HEXAGON:	8
6	PAOZZ	19200	9354364-2	STUD, SHOULDERED AND STEPPED:	2
7	PAOZZ	19200	9378072	HOLDER, DOOR: FUTURE SPARES WILL NOT BE CARC.... PAINTED	2
8	PDOOO	19200	9354412	WRENCH, OPEN END: FUTURE SPARES WILL NOT BE CARC PAINTED SEE AR305752-A DEPICTING BREAKOUT OF WRENCH	1
9	PAOZZ	19200	9381357	BOLT, RIBBED SHOULDER:	16
10	PAOZZ	19200	9352729-1	CASTER, SWIVEL: FRONT, WITH BRAKE	2
11	PAOZZ	19200	9352729-2	CASTER, SWIVEL: REAR, WITHOUT BRAKE	2
12	PAOOO	19200	9369985	STAY, FOLDING: LEFT- FUTURE SPARES WILL NOT BE CARC PAINTED	1

END OF FIGURE

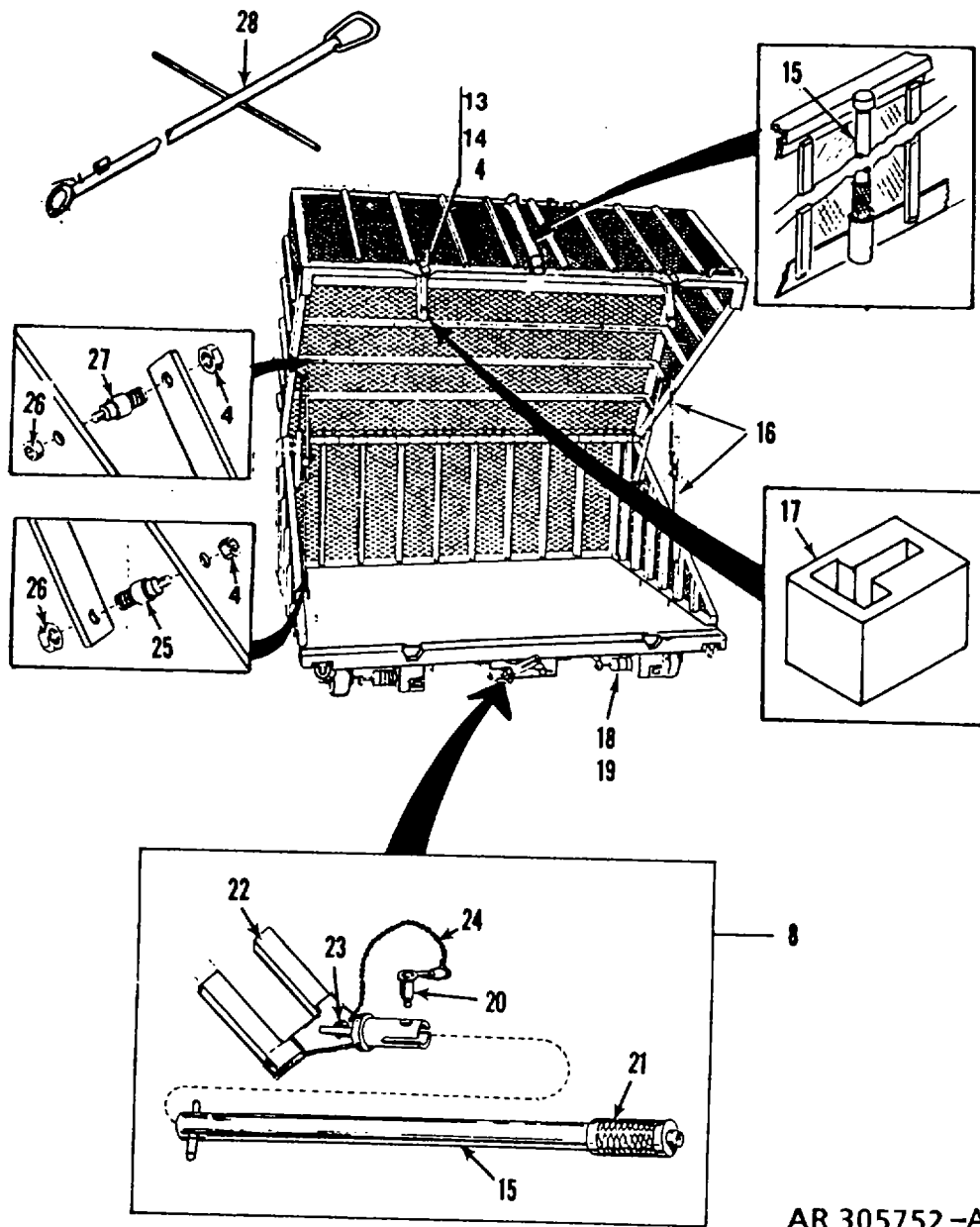

FIGURE B1. WEAPON SECURITY CAGE (Part 2 of 2)

B10

Section II

(1) ITEM NO	(2) SMR CODE	(3) CAGEC	(4) PART NUMBER	(5) DESCRIPTION AND USABLE ON CODES(UOC)	(6) QTY
GROUP 01 WEAPON SECURITY CAGE 9349591 (19200) (CONTINUED)					
FIGURE B1 WEAPON SECURITY CAGE (PART 2 OF 2)					
13	PAOZZ	19200	9378073	CATCH, CLAMPING: FUTURE SPARES WILL NOT BE CARC PAINTED	2
14	PAOZZ	96906	MS35307-308	SCREW, CAP, HEXAGON HEAD: STL, PSVT, .25-20UNC-2A X 2.0 IN. 1, .428 IN. WAF.....	4
15	PAOZZ	19200	9354410	HANDLE. EXTENSION, WRENCH: FUTURE SPARES WILL NOT BE CARC PAINTED	1
16	PAOOO	19200	9369986	STAY, FOLDING: RIGHT- FUTURE SPARES WILL NOT BE.. CARC PAINTED	1
17	PAOZZ	19200	9354602	PAD, CUSHIONING:	2
18	PAOZZ	19200	9349435	LOCKING DEVICE, SECURITY:	2
19	PAOZZ	19200	9354312	INSTALLATION KIT, LOCK:	1
20	PAOZZ	19200	9378209	PIN, QUICK RELEASE:	1
21	PAOZZ	19200	9381474	KEY, SOCKET HEAD SCREW:.....	1
22	PAOZZ	19200	9354411	FORK, CASTER, HAND: FUTURE SPARES WILL NOT BE.... CARC PAINTED	1
23	PAOZZ	96906	MS21097-06004	SCREW, SELF-LOCKING:	1
24	PAOZZ	80205	NAS1201C10A18B	CHAIN ASSEMBLY, SINGLE LEG:	1
25	PAOZZ	19200	9354364-3	STUD, SHOULDERED AND STEPPED:	2
26	PAOZZ	96906	MS51943-35	NUT, SELF-LOCKING, HEXAGON: STL, CD-PLD, .375-..... 16UNC-3B, PLSTC INSERT	4
27	PAOZZ	19200	9354364-4	STUD, SHOULDERED AND STEPPED:.....	2
28	PEOOO	19200	9395739	TOWBAR, MOTOR VEHICLE: FUTURE SPARES WILL NOT BE CARC PAINTED	1

END OF FIGURE

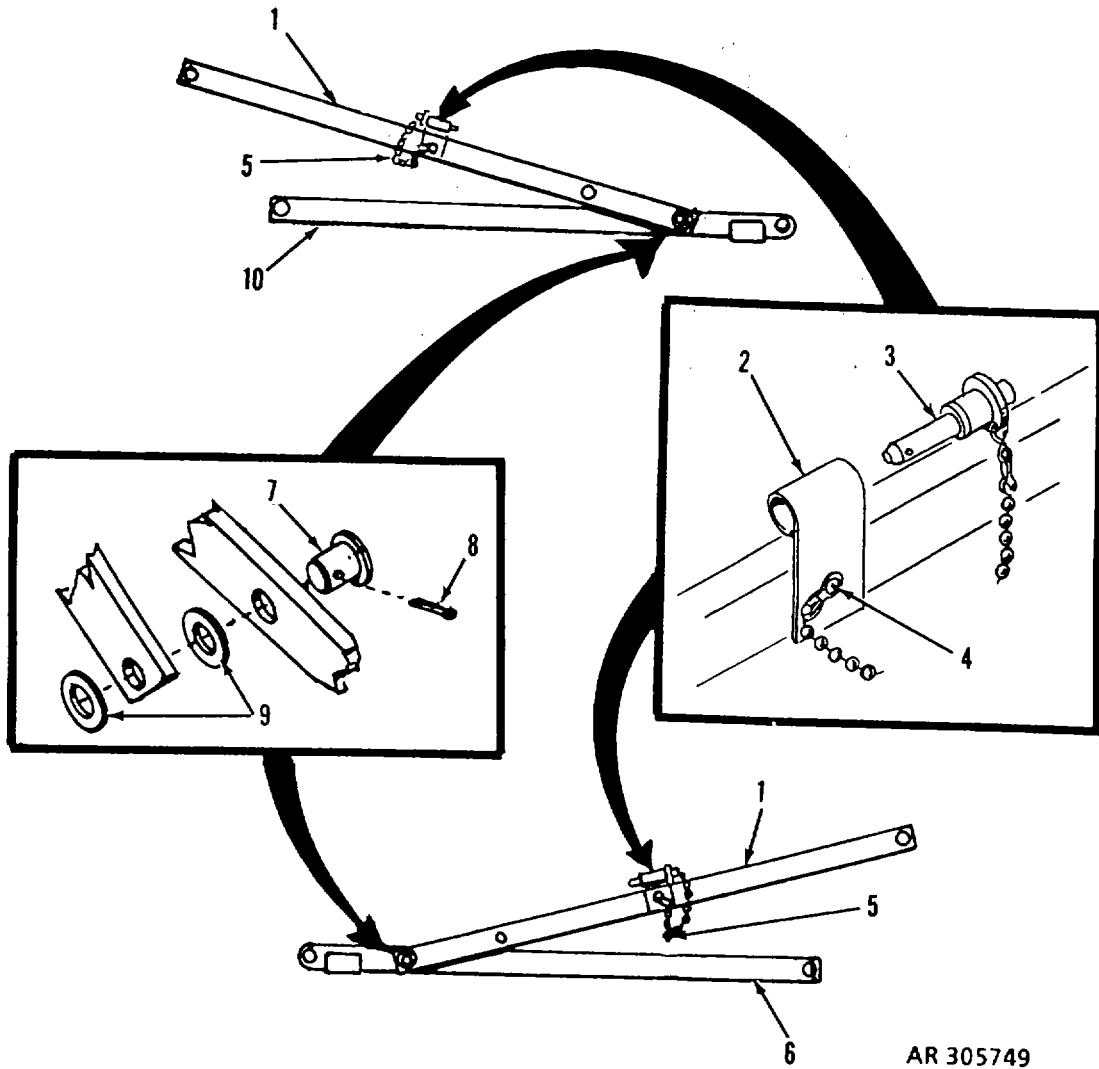

AR 305749

FIGURE B2. STAY, FOLDING: LEFT AND RIGHT

Section II

(1) ITEM NO	(2) SMR CODE	(3) CAGEC	(4) PART NUMBER	(5) DESCRIPTION AND USABLE ON CODES(UOC)	(6) QTY
				GROUP 0101 STAY, FOLDING 9369985 (19200) LEFT 9369986 (19200) RIGHT	
				FIGURE B2 STAY, FOLDING: LEFT AND RIGHT	
1	XAOZZ	192(X)	9354315	STRUT, WELDMENT: LEFT AND RIGHT	4
2	PAOZZ	192(X)	12624559	RECEPTACLE, QUICK RELEASE PIN: LEFT AND RIGHT	2
3	PAOZZ	96906	MS17984C813	PIN, QUICK RELEASE: LEFT AND RIGHT	2
4	PAOZZ	96906	MS35206-230	SCREW, MACHINE: LEFT AND RIGHT	2
5	PAOZZ	80205	NAS1201C10A18B	CHAIN ASSEMBLY, SINGLE LEG: STL, BEADED CHAIN.	3
				TERMINAL LATCH, 9.0 IN. OA LG LEFT AND RIGHT	
6	XAOZZ	19200	9354317-2	STRUT, WELDMENT: LEFT	1
7	PAOZZ	969(16)	MS35810-6	PIN, STRAIGHT, HEADED: LEFT AND RIGHT	2
8	PAOZZ	96906	MS24665-353	PIN, COTTER: LEFT AND RIGHT	1
9	PAOZZ	88044	AN960-816	WASHER, FLAT: STL, CD-PLD, .87 IN. OD, .505 IN. 1D. .053 IN. THK LEFT AND RIGHT	4
10	XAOZZ	19200	9354317-1	STRUT WELDMENT: RIGHT	1

END OF FIGURE

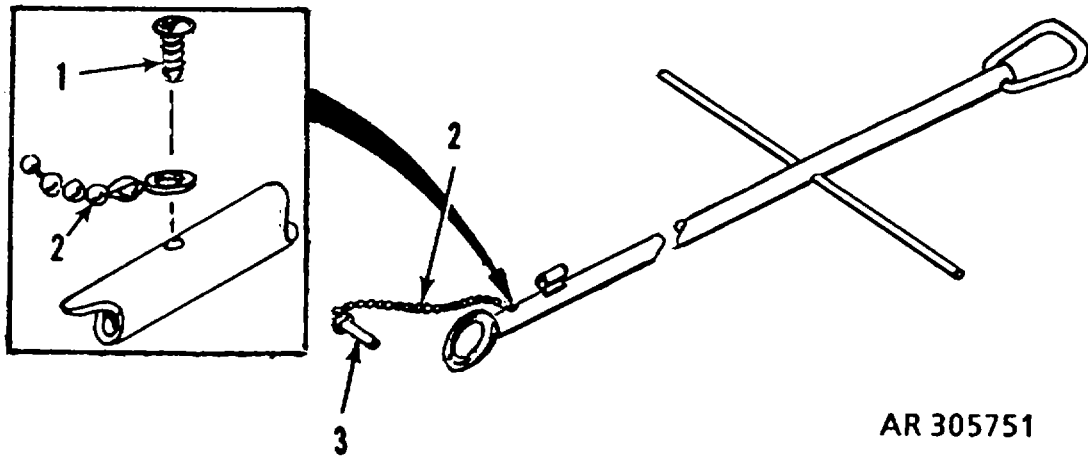

FIGURE B3. TOWBAR, MOTOR VEHICLE

B14

Section II

(1) ITEM NO	(2) SMR CODE	(3) CAGEC	(4) PART NUMBER	(5) DESCRIPTION AND USABLE ON CODES(UOC)	(6) QTY
-------------------	--------------------	--------------	-----------------------	---	------------

GROUP 0102 TOWBAR, MOTOR VEHICLE
9395739(19200)

FIGURE B3 TOWBAR, MOTOR VEHICLE

1	PAOZZ	96906	MS21097-06004	SCREW, SELF-LOCKING:	3
2	PAOZZ	80205	NAS1201C10B14A	CHAIN ASSEMBLY, SINGLE LEG:	1
3	XDOZZ	81349	M45952/1-C12-22	PIN, QUICK RELEASE:	1

END OF FIGURE

B15

**SECTION III
SPECIAL TOOLS**

Section III. Special Tools List. Not required.

B16

SECTION IV

CROSS-REFERENCE INDEXES
NATIONAL STOCK NUMBER INDEX

STOCK NUMBER	FIG.	ITEM	STOCK NUMBER	FIG.	ITEM
5310-00-061-4650	B1	4	5340-01-151-6497	B1	18
5315-00-140-1938	B2	7	5340-01-151-7852	B1	13
5310-00-167-0823	B2	9	5120-01-158-8262	B1	8
5305-00-207-8253	B1	14	5307-01-184-4050	B1	6
4010-00-451-4544	B1	24	5307-01-184-4151	B1	25
4010-00-451-4544	B2	5	5340-01-184-4052	B1	12
5310-00-488-3888	B1	2	5307-01-184-4053	B1	3
5305-00-501-2380	B1	23	5340-01-184-5721	B1	16
5305-00-501-2380	B3	1	5307-01-184-5722	B1	27
5310-00-814-0673	B1	5	5120-01-187-3663	B1	21
5315-00-839-5822	B2	8	5120-01-187-3664	B1	15
5305-00-889-3000	B2	4	5120-01-187-3665	B1	22
5315-00-904-4783	B2	3	5340-01-189-2791	B1	1
4010-00-933-2252	B3	2	5306-01-201-3336	B1	9
5310-00-935-9021	B1	26	8140-01-213-2806	B1	17
5340-01-150-8948	B1	7	5340-01-225-5724	B2	2
5340-01-150-8949	B1	19	2540-01-227-6833	B1	28
5340-01-151-1741	B1	10	5315-01-306-9691	B1	20
5340-01-151-6494	B1	11			

Section IV
CROSS-REFERENCE INDEXES
PART NUMBER INDEX

CAGEC	PART NUMBER	STOCK NUMBER	FIG.	ITEM
19200	12624559	5340-01-225-5724	B2	2
19200	9349435	5340-01-151-6497	B1	18
19200	9352729-1	5340-01-151-1741	B1	10
19200	9352729-2	5340-01-151-6494	B1	11
19200	9354312	5340-01-150-8949	B1	19
19200	9354315		B2	1
19200	9354317-1		B2	10
19200	9354317-2		B2	6
19200	9354364-1	5307-01-184-4053	B1	3
19200	9354364-2	5307-01-184-4050	B1	6
19200	9354364-3	5307-01-184-4051	B1	25
19200	9354364-4	5307-01-184-5722	B1	27
19200	9354410	5120-01-187-3664	B1	15
19200	9354411	5120-01-187-3665	B1	22
19200	9354412	5120-01-158-8262	B1	8
19200	9354602	8140-01-213-2806	B1	17
19200	9369985	5340-01-184-4052	B1	12
19200	9369986	5340-01-184-5721	B1	16
19200	9369995	5340-01-189-2791	B1	1
19200	9378072	5340-01-150-8948	B1	7
19200	9378073	5340-01-151-7852	B1	13
19200	937820)9	5315-01-306-9691	B1	20
19200	9381357	5306-01-201-3336	B1	9
19200	9381474	5120-01-187-3663	B1	21
19200	9395739	2540-01-227-6833	B1	28
88044	AN960-816	5310-00-167-0823	B2	9
81349	M45952/1-C12-22		B3	3
96906	MS 17984C813	5315-00-904-4783	B2	3
96906	MS21097-060104	5305-00-501-2380	B1	23
96906	MS21097-06004	5305-00-501-2380	B3	1
96906	MS24665-353	5315-00-839-5822	B2	8
96906	MS35206-230	5305-00-889-3000	B2	4
96906	MS35307-308	5305-00-207-8253	B1	14
96906	MS35810-6	5315-00-141-1938	B2	7
96906	MS51943-31	5310-00-061-4650	B1	4
96906	MS51943-33	5310-00-814-0673	B1	5
96906	MS51943-35	5310-00-935-9021	B1	26
96906	MS51943-40	5310-00-488-3888	B1	2
80205	NAS1201C10A18B	4010-00-451-4544	B1	24
80205	NAS1201C10A18B	4010-00-451-4544	B2	5
80205	NAS1201C10B14A	4010-00-933-2252	B3	2

Section IV
CROSS-REFERENCE INDEXES
FIGURE AND ITEM NUMBER INDEX

FIG.	ITEM	STOCK NUMBER	CAGEC	PART NUMBER
B1	1	5340-01-189-2791	19200	9369995
B1	2	5310-00-488-3888	96906	MS51943-40
B1	3	5307-01-184-4053	19200	9354364-1
B1	4	5310-00-061-4650	96906	MS51943-31
B1	5	5310-00-814-0673	96906	MS51943-33
B1	6	5307-01-184-4050	19200	9354364-2
B1	7	5340-01-150-8948	19200	9378072
B1	8	5120-01-158-8262	19200	9354412
B1	9	5306-01-201-3336	19200	9381357
B1	10	5340-01-151-1741	19200	9352729-1
B1	11	5340-01-151-6494	19200	9352729-2
B1	12	5340-01-184-4052	19200	9369985
B1	13	5340-01-151-7852	19200	9378073
B1	14	5305-00-207-8253	96906	MS35307-308
B1	15	5120-01-187-3664	19200	9354410
B1	16	5340-01-184-5721	19200	9369986
B1	17	8140-01-213-2806	19200	9354602
B1	18	5340-01-151-6497	19200	9349435
B1	19	5340-01-150-8949	19200	9354312
B1	20	5315-01-306-9691	19200	9378209
B1	21	5120-01-187-3663	19200	9381474
B1	22	5120-01-187-3665	19200	9354411
B1	23	5305-00-501-2380	96906	MS21097-06004
B1	24	4010-00-451-4544	80205	NAS1201C10A18B
B1	25	5307-01-184-4051	19200	9354364-3
B1	26	5310-00-935-9021	96906	MS51943-35
B1	27	5307-01-184-5722	19200	9354364-4
B1	28	2540-01-227-6833	19200	9395739
B2	1		19200	9354315
B2	2	5340-01-225-5724	19200	12624559
B2	3	5315-00-904-4783	96906	MS17984C813
B2	4	5305-00-889-3000	96906	MS35206-230
B2	5	4010-00-451-4544	80205	NAS1201C10A18B
B2	6		19200	9354317-2
B2	7	5315-00-140-1938	96906	MS35810-6
B2	8	5315-00-839-5822	96906	MS24665-353
B2	9	5310-00-167-0823	88044	AN960-816
B2	10		19200	9354317-1
B3	1	5305-00-501-2380	96906	MS21097-06004
B3	2	4010-00-933-2252	80205	NAS1201C10B14A
B3	3		81349	M45952/1-C12-22

THIS PAGE INTENTIONALLY LEFT BLANK

B20

APPENDIX C MAINTENANCE ALLOCATION CHART (MAC)

Section I. INTRODUCTION

C-1. GENERAL

a. This section provides a general explanation of maintenance and repair functions authorized at various maintenance categories.

b. The Maintenance Allocation Chart (MAC) in section II designates overall authority and responsibility for the performance of maintenance functions on the identified end item or component. The application of the maintenance functions to the end item or component will be consistent with the capacities and capabilities of the designated maintenance categories.

c. Section III lists the tools and test equipment required for each maintenance function as referenced in section II.

d. Section IV contains supplemental instructions and explanatory notes for a particular maintenance function.

C-2. MAINTENANCE FUNCTIONS

Maintenance functions will be limited to and defined as follows:

a. Inspect. To determine the serviceability of an item by comparing its physical, mechanical, and/or electrical characteristics with established standards through examination.

b. Test. To verify serviceability by measuring, pneumatic, hydraulic, or electrical characteristics of an item and compiling those characteristics with prescribed standards.

c. Service. Operations required periodically to keep an item in proper operating condition, i.e., to clean,

to preserve, to drain, to paint, or to replenish fuel, lubricants, chemical fluids, or gases.

d. Remove/Install. To remove and install the same item when required to perform service or other maintenance functions. Install may be the act of emplacing, seating, or fixing into position a spare, repair part, or component or assembly, in a manner to allow the proper functioning of the end item.

e. Replace. To remove an unserviceable item and install a serviceable counterpart in its place.

f. Repair. The application of maintenance services¹, including troubleshooting², removal/installation, and disassembly/assembly³ procedures, and maintenance actions⁴ to identify troubles and restore serviceability to an item by correcting specific damage, fault, malfunction, or failure in a part, subassembly, component, end item, or system.

C-3. EXPLANATION OF COLUMNS IN MAC, SECTION II

a. Column 1, Group Number. Column 1 lists functional group code numbers, the purpose of which is to identify maintenance significant components, assemblies, subassemblies, and modules with the next higher assembly

¹Services - inspect, test, service, adjust, align, calibrate, and/or replace.

²Troubleshooting - the process of investigating and detecting the cause of equipment malfunctioning; the act of isolating a fault within a system or unit under test.

³Disassemble/assemble - encompasses the step-by-step taking apart (or breakdown) of a spare/functional group coded item to the level of its least component identified as maintenance significant (i.e., assigned as SMR code) for the level of maintenance under consideration.

⁴Actions - welding, grinding, riveting, straightening, facing, remachining, and/or resurfacing.

b. Column 2, Component/Assembly. Column 2 contains the names of components, assemblies, subassemblies, and modules for which maintenance is authorized.

c. Column 3, Maintenance Function. Column 3 lists the functions to be performed on the item listed in Column 2. (For detailed explanation of these functions, see paragraph C-2 "Maintenance Functions" on page C-1.

d. Column 4, Maintenance Level. Column 4 specifies, by the listing of a work time figure in the appropriate subcolumn(s), the level of maintenance authorized to perform the function listed in column 3. This figure represents the active time required in hours to perform that maintenance function at the indicated level of maintenance. If the number of complexity of the tasks within the listed maintenance function vary at different maintenance levels, appropriate work time figures will be shown for each level. The work time figure represents the average time required to restore an item (assembly, subassembly, component, module, end item, or system) to a serviceable condition under typical field operation conditions. This time includes preparation time, troubleshooting time, and quality assurance/quality control time in addition to the time required to perform the specific tasks identified for the maintenance functions authorized in the maintenance allocation chart. The symbol designations for the various maintenance categories are as follows:

- C - Operator or crew
- O - Unit maintenance
- F - Direct support maintenance
- H - General support maintenance
- D - Depot maintenance

e. Column 5, Tools and Equipment. Column 5 specifies, by code, those common tool sets (not individual tools) and special tools, TMDE, and support equipment required to perform the designated function.

f. Column 6, Remarks. This column shall, when applicable, contain a letter code, in alphabetic order, which shall be keyed to the remarks contained in section IV.

C-4. EXPLANATION OF COLUMNS IN TOOL AND TEST EQUIPMENT REQUIREMENTS, SECTION III

a. Column 1, Reference Code. The tools and test equipment reference code correlates with a code used in the MAC, section II, column 5.

b. Column 2, Maintenance Level. The lowest level of maintenance authorized to use the tool or test equipment.

c. Column 3, Nomenclature. Name or identification of the tool or test equipment.

d. Column 4, National/NATO Stock Number. The national/NATO stock number of the tool or test equipment.

e. Column 5, Tool Number. The manufacturer's part number.

C-5. EXPLANATION OF COLUMNS IN REMARKS, SECTION IV

a. Column 1, Reference Code. The code recorded in column 6, section II.

b. Column 2, Remarks. This column lists information pertinent to the maintenance function being performed as indicated in the MAC, section II.

Section II. MAINTENANCE ALLOCATION CHART

(1) GROUP NUMBER	(2) COMPONENT/ ASSEMBLY	(3) MAINTENANCE FUNCTION	(4) MAINTENANCE LEVEL UNIT		(5) TOOLS AND EQUIPMENT	(6) REMARKS
			C	O		
1	Caster	Test Replace	.2	.2	16, 19	
2	Caster brake	Test Adjust		.3	13, 16, 18, 19	
3	Caster shoulder bolt	Inspect Replace		.5	1, 2, 8, 18, 19	
4	Caster lubrication	Inspect Lube	.1	.1	5	
5	Cover hinge	Inspect Lube	.1	.1	4	
6	Gas spring and alter- nate procedure	Inspect Test Replace		.75	16, 17, 18, 19	
7	Combination lock	Inspect Replace	.3	.3	3, 7	
8	Quick release pin and	Test Replace	.3	.3	10	
9	Safety bracket	Inspect, Test, Replace		.5	1, 18, 9	
10	External latch	Inspect Replace	.3	.3	1, 18, 19	

Section III. TOOLS AND TEST EQUIPMENT REQUIREMENTS

REFERENCE CODE	MAINTENANCE CATEGORY	NATIONAL/NATO STOCK NUMBER	TOOL DESCRIPTION
1	C, O	5120-00-240-8702	ADAPTER SOCKET WRENCH: 3/8-inch male sq end, 1/2-inch female sq end
2	C, O	5120-00-061-8542	HAMMER, HAND: machinist's ball peen, 12 oz hd wt
3	C, O	5120-00-935-4641	KEY SET, SOCKET HEAD SCREW:
4	C, O	4390-00-253-2478	LUBRICATING GUN, HAND: lever operated, 14 oz cap. 6000 psi pressure, ext 6-1/2-in. 1, hyd coupler, w/loader fitting
5	C, O	4930-00-985-2604	OILER, HAND: 6 oz cap press fed by intl pump stl body nkl pld finish 1-1/8-in. bottom dia 1 spout w/removable tip, w/closure cap atchd w/o holder bracket
6	C, O	5120-00-223-7397	PLIERS, SLIP JOINT: str nose, comb w/cutter, 8-inch size
7	C, O	5120-00-278-0352	PLIERS, SLIP JOINT: str nose, multiple tongue and groove, 10 inch size
8	C, O	5120-00-240-6104	PUNCH DRIVE PIN: 9 str punches w/case
9	C, O	5120-00-237-8173	SCREWDRIVER, CROSS TIP: Phillips No. 0, 4-inch blade plstc hdl
10	C, O	5120-00-237-8174	SCREWDRIVER, CROSS TIP: Phillips No. 1, 3-inch blade, plstc hdl
11	C, O	5120-00-222-8852	SCREWDRIVER, FLAT TIP: plstc hdl, 1/4-inch w/flared tip, 4-inch blade
12	C, O	5120-00-236-2140	SCREWDRIVER, FLAT TIP: plstc hdl, 1/8-inch w/flared tip, 2-inch blade
13	C, O	5120-00-260-4837	SCREWDRIVER, FLAT TIP: plstc hdl, 3/16-inch w/str sided tip, 8-inch blade lg
14	C, O	5120-00-243-1673	SOCKET WRENCH ATTACHMENT, SCREWDRIVER: socket hd screw 1/4-inch hex plug end 3/8-inch sq dr end, w/removable hex bit

REFERENCE CODE	MAINTENANCE CATEGORY	NATIONAL/NATO STOCK NUMBER	TOOL DESCRIPTION
15	C, 0	5120-00-596-1199	SOCKET WRENCH ATTACHMENT, SCREWDRIVER: socket hd screw 3/8-inch hex plug end, 3/8-inch dr sq end, w/removable hex bit
16	C, 0	5120-00-683-8602	SOCKET WRENCH ATTACHMENT, SCREWDRIVER: socket hd screw 5/16-inch hex plug end, 3/8-inch dr sq end, w/removable hex bit
17	C, 0	5120-00-449-8083	WRENCH, ADJUSTABLE: sgl hd type, 0 to 1.135 inch opngs, 10 inches long
18	C, 0	5120-00-148-7917	WRENCH SET, COMB BOX AND OPEN END: w/container
19	C, 0	5120-00-322-6231	WRENCH SET, SOCKET: 3/8-inch sq dr 12 pt, opngs, w/case

Section IV. MAINTENANCE ALLOCATION CHART (MAC) REMARKS

Reference Code	Remarks
----------------	---------

NOT APPLICABLE

NOTE

Unless otherwise noted, no higher level (direct support, general support or depot) will be performed. Guidance from depot will be provided by Picatinny Arsenal, NJ.

THIS PAGE INTENTIONALLY LEFT BLANK

**APPENDIX D
EXPENDABLE AND DURABLE ITEMS LIST**

Section I. INTRODUCTION

D-1. SCOPE

This appendix lists expendable and durable items that you will need to operate and maintain the weapon security cage. This listing is for information only and is not authority to requisition the listed items. These items are authorized to you by CTA 50-970, Expendable/Durable Items (except medical, class V repair parts, and heraldic items), or CTA 8-100, Army Medical Department Expendable/Durable Items.

D-2. EXPLANATION OF COLUMNS.

a. *Column 1. Item number.* This number is assigned to the entry in the listing and is referenced in

the narrative instructions to identify the item (e.g. "Use cleaning compound, item 5, Appendix D".)

b. *Column 2. Level.* This column identifies the lowest level of maintenance that requires the item.

c. *Column 3. National stock number:* This is the national stock number assigned to the item which you can use to requisition it.

d. *Column 4. Item name, description, Commercial and Government Entity Code (CAGEC), and part number.* This provides the other information you need to identify the item.

e. *Column 5. Unit of Measure.* This code shows the physical measurement or count of an item, such as gallon, dozen, gross, etc.

Section II. EXPENDABLE/DURABLE SUPPLIES AND REQUIREMENTS LIST

Item Number	Level	National stock number	Item Name, Description, CAGEC, Part Number	U/M
1	O	8040-00-841-9773	Adhesive, Class I, TYPE II, 1 pint can MIL-A-24179 (81349)	PT
2	O	8040-00-118-2695	Adhesive, Sealant, Sil. RTV, 3 oz. MIL-A-46106	OZ
3	O	8020-00-260-1306	Brush, Varnish: Hog Bristle, Fl, 1 in. w, 2-1/4 in. min. exposed ig, Cl 1, Gr B H-B-695 (81349)	EA
4	O	7920-00-291-5815	Brush, Wire, Scratch: St[wire, curved hdle, rocker rect face, 4 rows wide, 18 rows long, 6 in. long brush part, 14 in. Oa lg. HB 178 (81348)	EA
5	O	6850-00-105-3084	Cleaning Compound, Solvent: 16 oz, aerosol can MIL-C-81302 (81349)	CN
6	O	5350-00-161-9066	Cloth, Abrasive: Al-Oxide, Grit No. 100, 9 in. w, 11 in. lg, TYPE 1, Cl 1 P-C 451 (81348)	PG
7	O	8305-00-222-2423	Cloth, Cheesecloth: Cotton, 38-1/2 in. w, TYPE 1, Cl 1 CCCC 440 (81348)	YD

**Section II. EXPENDABLE/DURABLE SUPPLIES
AND REQUIREMENTS LIST - Continued**

Item Number	Level	National stock number	Item Name, Description, CAGEC, Part Number	U/M
8	O	7930-00-249-8036	Detergent, General Purpose 5 lb TYPE 1 Flake or powder form P-D-220 (82348)	CO
9	O	9150-00-190-0904	Grease, Automotive and Artillery: Corr, Evaporation and oxidation resistant, 1.75 lb can MIL-G-10924 (81349)	CN
10	O	6810-00-983-8551	Isopropyl Alcohol, Technical: 1 qt, grA TT-I-735 (81348)	QT
11	O		Lock/Sealer, Thread Loctite No. 222	
12	O	8010-00-338-7789	Lubricant, Corrosion Preventive 16 oz	CN
13	O	9150-00-168-2000	Lubricant, Solid Film: (anti-seize compound) 1G oz can MIL-L-46147 (81349)	CN
14	O	9150-00-231-2361	Lubricating Oil, General Purpose: Corres and salt spray res, 1 qt MIL-L-3150 (81349)	QT
15	O	8135-00-068-9466	Plastic sheet: polyethylene, transparent, 100 ft. lg 3 ft. w, 0.004 in. thk, TYPE 1, grade A, Finish I LP 378 (81348)	RO
16	O	8010-01-144-9885	Polyurethane Coating, black 37038, TYPE 1, 1 qt. Comp. A, 1/2 pt. Comp. B, SL: 4 MIL-C-46168 (81349)	KT
17	O	8010-01-141-2419	Polyurethane Coating, black 37030, TYPE 1, 1 qt. Comp. A, 1/2 pt. Comp. B, SL: 4 MIL-C-46168 (81349)	KT
18	O	8010-00-292-1127	Primer Coating: zn-chromate Red, 1 gal can TT-P-664 (81348)	CL
19	O	8010-00-558-7026	Thinner, Paint, Mineral Spirits: TYPE 1, 5 gal TT-T-291 (81348)	CN
20	O	8010-01-229-7546	Polyurethane Coating, green 383, no. 34094, 1 qt, SL: 4 MIL-C-53039 (81349)	QT
21	O	8010-01-229-9561	Polyurethane Coating, green 383, no. 34094, 1 gal, SL: 4 MIL-C-53039 (81349)	GL
22	O	8010-01-229-7540	Polyurethane Coating, black 383, no. 37030, 1 qt, SL: 4 MIL-C-53039 (81349)	QT
23	O	8010-01-229-7541	Polyurethane Coating, black 383, no. 37030, 1 qt, SL: 4 MIL-C-53039 (81349)	GL
24	O	8010-01-162-5578	Polyurethane Coating, green 383, TYPE 2, 1 gal. Comp A, 1 qt Comp B, SL: 4 MIL-C-46168 (81349)	KT
25	O	8010-01-247-8885	Polyurethane Coating, aircraft yellow 33538, TYPE 2, 1 qt, Comp A, 1/2 pt, Comp B, SL: 4 MIL-C-46168 (81349)	KT

By Order of the Secretary of the Army:

GORDON R. SULLIVAN
General, United States Army
Chief of Staff

Official:

MILTON H. HAMILTON
Administrative Assistant to the
Secretary of the Army
06093

Distribution:

Controlled Distribution

*U.S. G.P.O.:1994-546-043:80731

RECOMMENDED CHANGES TO EQUIPMENT TECHNICAL PUBLICATIONS



THEN...JOT DOWN THE DOPE ABOUT IT ON THIS FORM. CAREFULLY TEAR IT OUT, FOLD IT AND DROP IT IN THE MAIL.

SOMETHING WRONG WITH PUBLICATION

FROM: (PRINT YOUR UNIT'S COMPLETE ADDRESS)

DATE SENT

PUBLICATION NUMBER

PUBLICATION DATE

PUBLICATION TITLE

BE EXACT PIN-POINT WHERE IT IS

PAGE NO.

PARA-GRAPH

FIGURE NO.

TABLE NO.

IN THIS SPACE, TELL WHAT IS WRONG AND WHAT SHOULD BE DONE ABOUT IT.

TEAR ALONG PERFORATED LINE

PRINTED NAME, GRADE OR TITLE AND TELEPHONE NUMBER

SIGN HERE

PIN: 072149-000